

**ASSEMBLY INSTRUCTIONS**  
**MONTERINGSANVISNINGAR**  
LINBANA ENKEL / ZIPLINE  
BLFJ201B

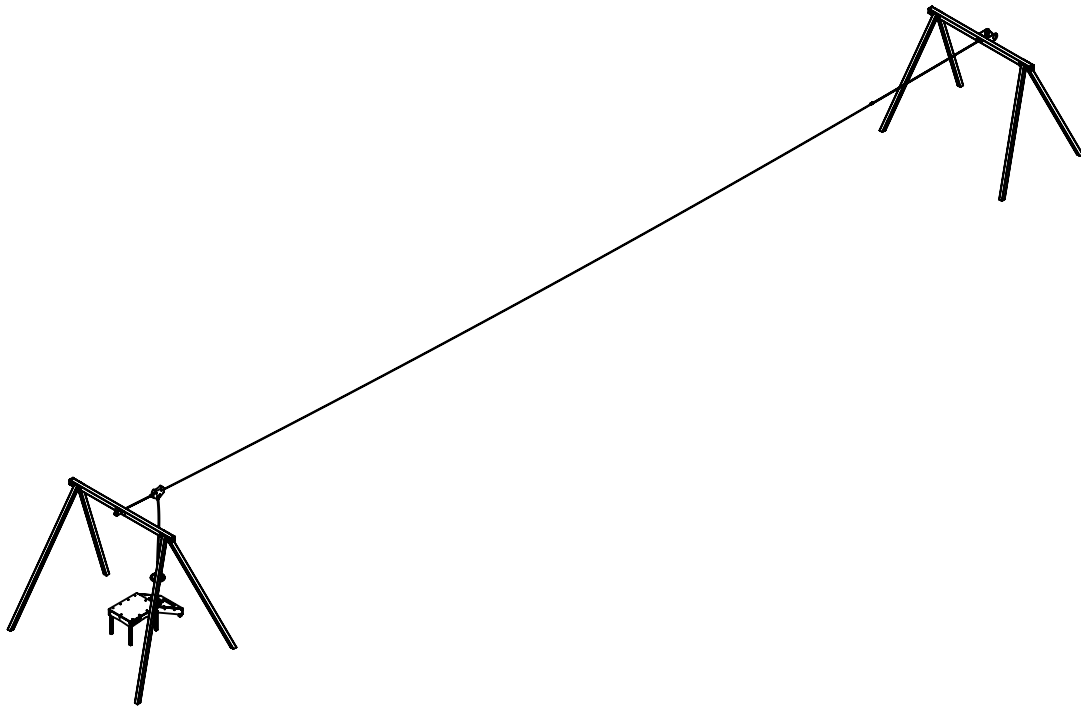

**MANUFACTURER / TILLVERKARE:**

Faberland Ltd./Kft.  
2119 Pécel, Pesti street 3.  
HUNGARY

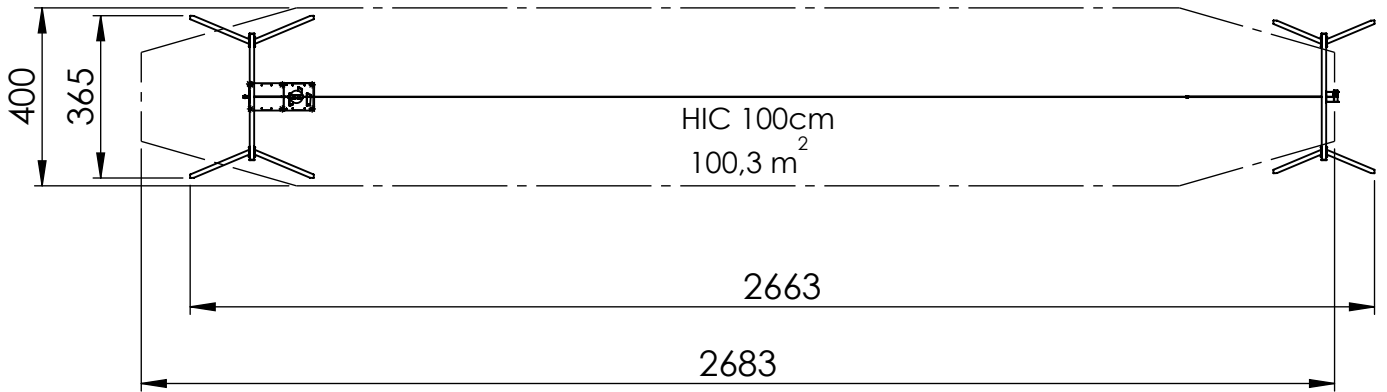
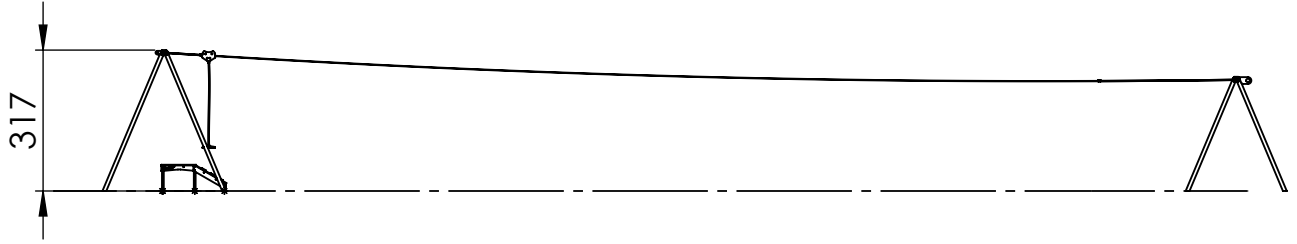

# FOOTING TYPES FUNDAMENT-TYPER

FLFJ201B

# broa.

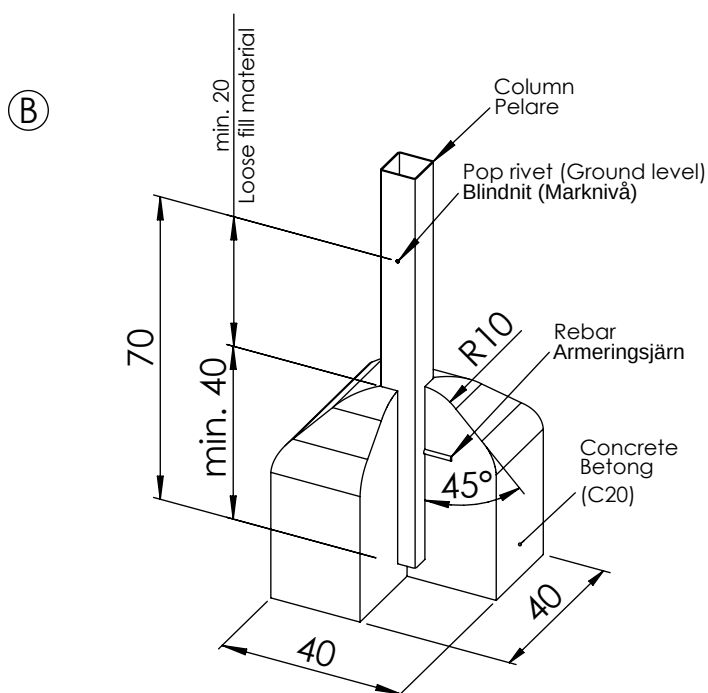
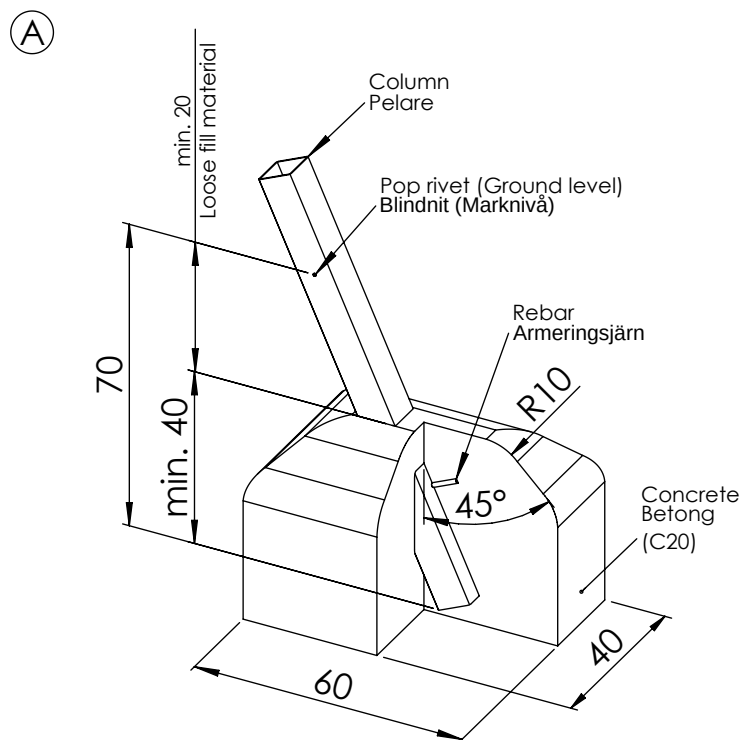

Leveling at 70 cm below ground/  
AVJÄMNING 70 CM UNDER MARKNIVÅ

FOOTING TYPES  
GRUNDLÄGGNINGSPÅN

BLFJ201B

broa.

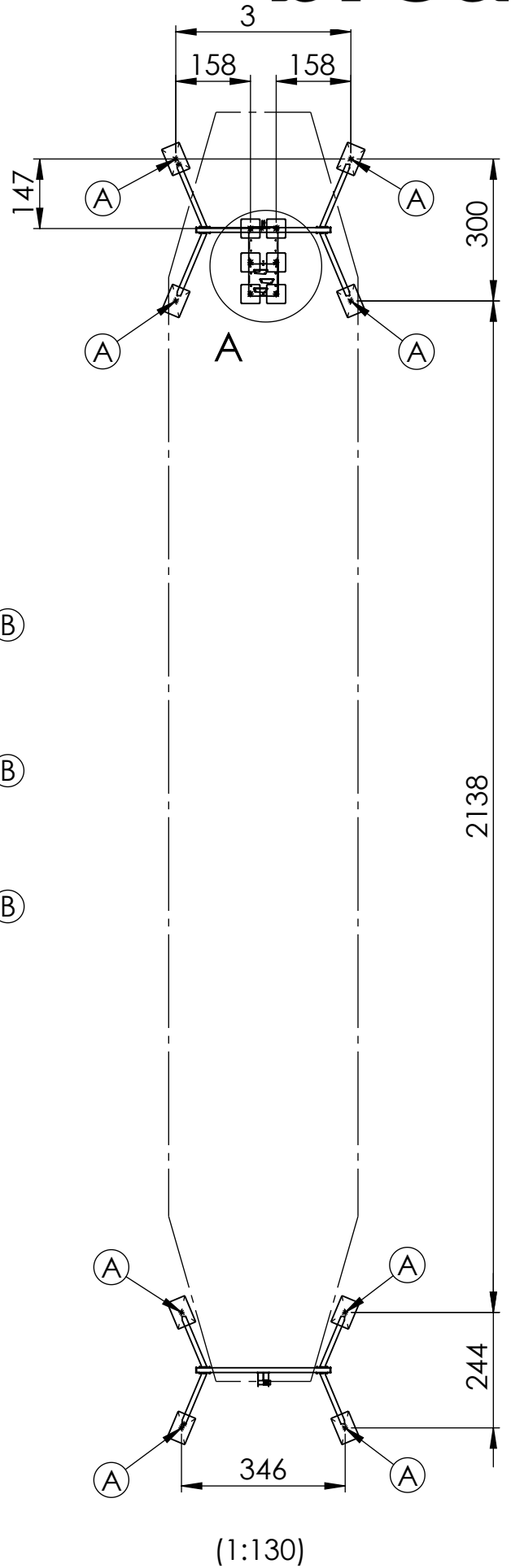
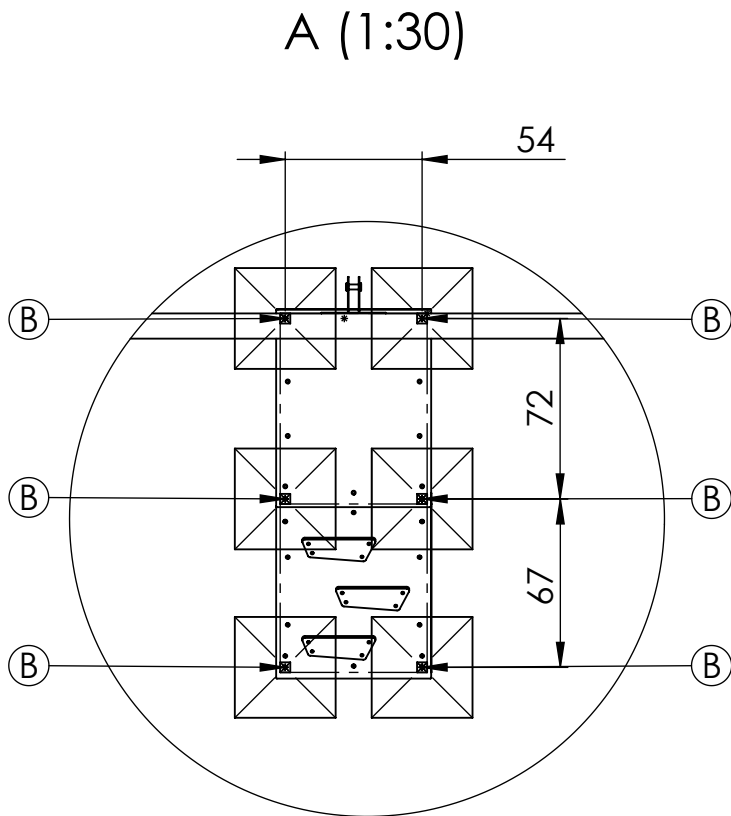

**FOOTING PLAN**  
**GRUNDLÄGGNING-**  
**SPLAN**

BLFJ201B 0

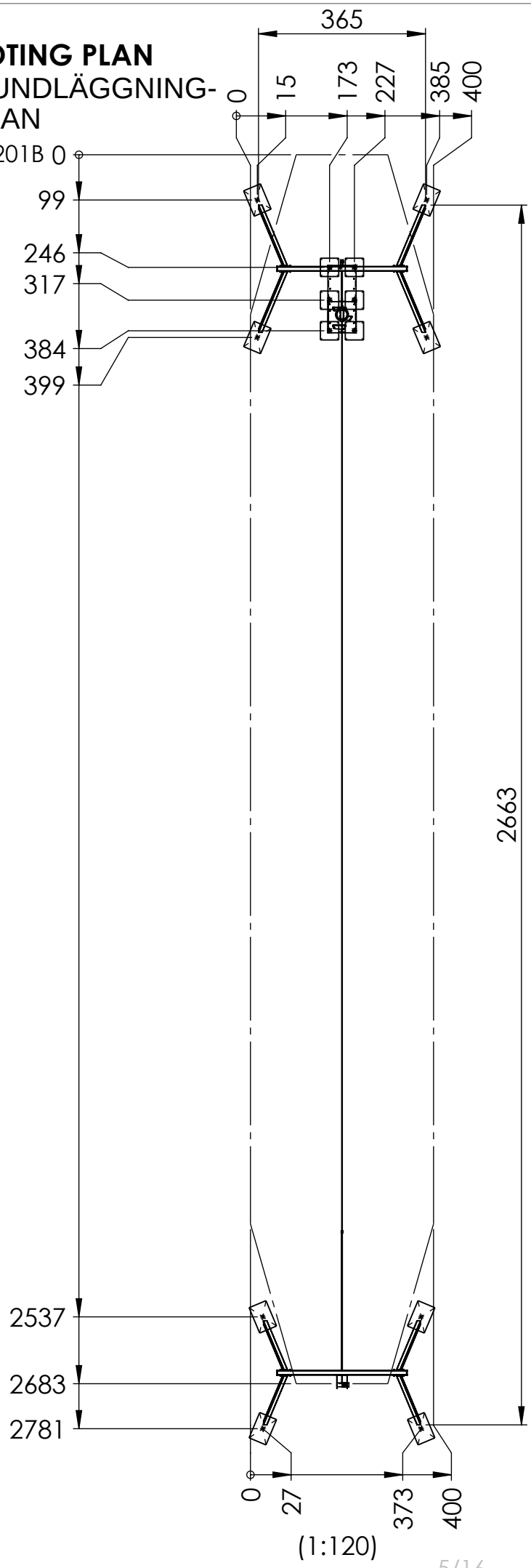



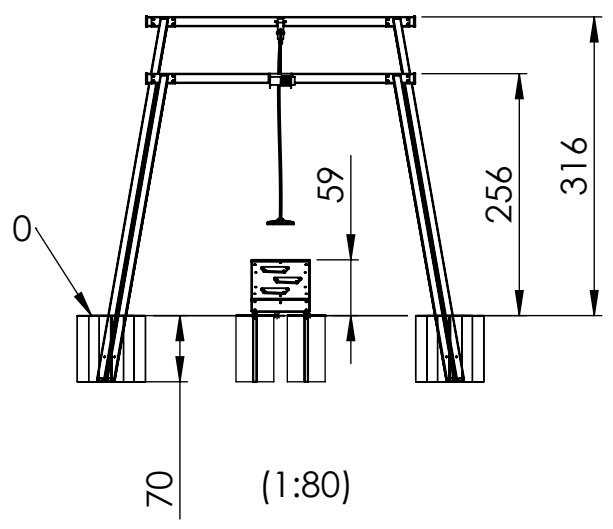











**broa.**

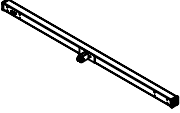
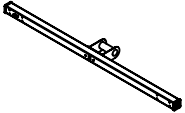
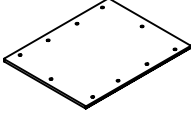
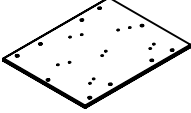
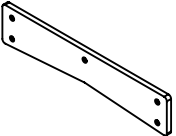
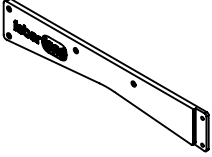
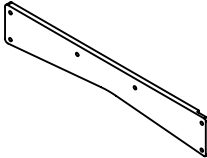
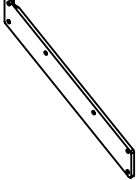
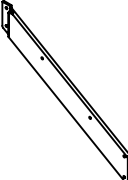
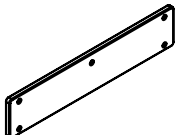
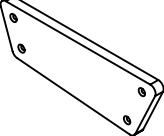

**BILL OF MATERIALS**  
MATERIALLISTA

BLFJ201B

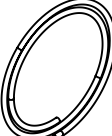
**broa.**

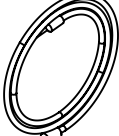
 x2 <b>DZ1</b> FAB21663	 x2 <b>DZ2</b> FAB21664	 x2 <b>DZ3</b> FAB21665	 x2 <b>DZ4</b> FAB21666	 x1 <b>Z1</b> FAB23825
 x1 <b>Z2</b> FAB23826	 x1 <b>Z3</b> FAB23827	 x1 <b>Z4</b> FAB23828	 x1 <b>Z5</b> FAB25005	 x1 <b>Z6</b> FAB25006
 x1 <b>FAB20639</b>	 x1 <b>FAB21100</b>	 x1 <b>FAB24994</b>	 x1 <b>FAB24995</b>	 x1 <b>FAB24996</b>
 x1 <b>FAB24997</b>	 x1 <b>FAB24998</b>	 x1 <b>FAB24999</b>	 x1 <b>FAB25000</b>	 x1 <b>FAB25001</b>
 x3 <b>FAB24935</b>	 x1 <b>FAB25121</b>	 x1 <b>FAB25122</b>	 x1 <b>FAB25123</b>	 x1 <b>FAB25124</b>

**BILL OF MATERIALS**  
**MATERIALLISTA**

BLFJ201B

**broa.**

 x1 <b>FAB25126</b>	 x12 <b>M6x25 FHCS</b>	 x12 <b>M6x12 FR</b>	 x38 <b>M8 FW</b>	 x38 <b>M8 SW</b>
 x32 <b>M8 CN</b>	 x32 <b>M10 FW</b>	 x32 <b>M10 SW</b>	 x32 <b>M10 CN</b>	 x16 <b>M10 ATR</b>
 x50 <b>M8x30 FHCS</b>	 x8 <b>M8x30 BHCS</b>	 x14 <b>D10 Rebar</b>	 x9 <b>FAB22996</b>	 x1 <b>FAB25003</b>
 x3 <b>FAB25004</b>	 x2 <b>FAB25007</b>	 x4 <b>FAB25028</b>	 x1 <b>Product label</b>	

**Assembly - 1. Platform**  
**MONTERING - 1. PLATFORM**  
 BLFJ201B

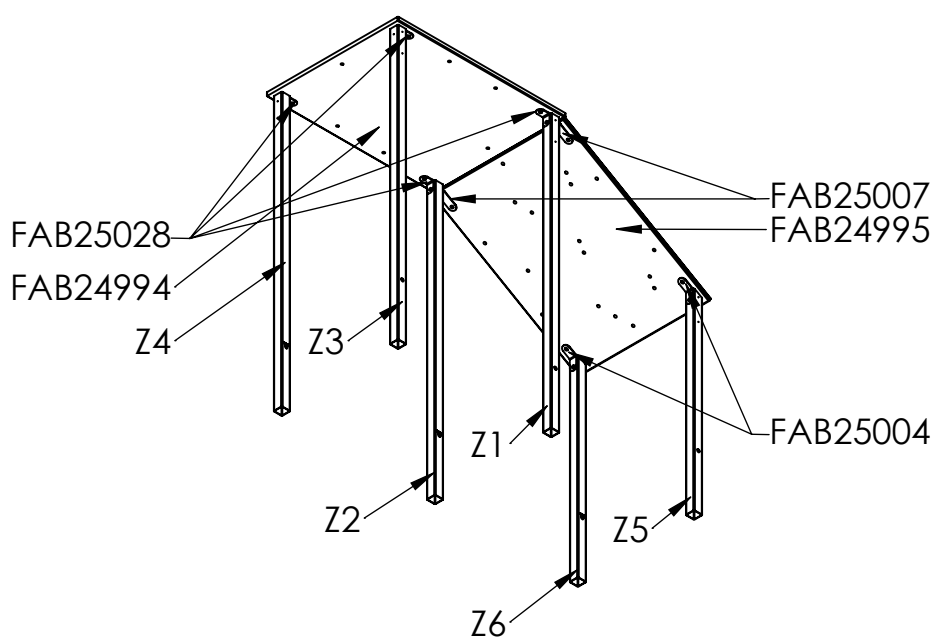
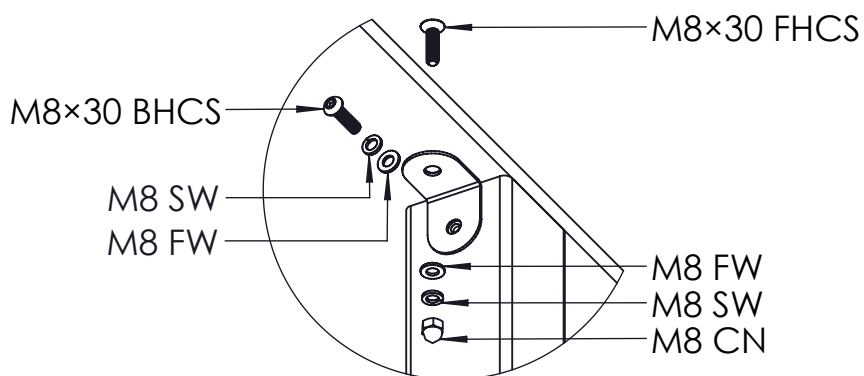
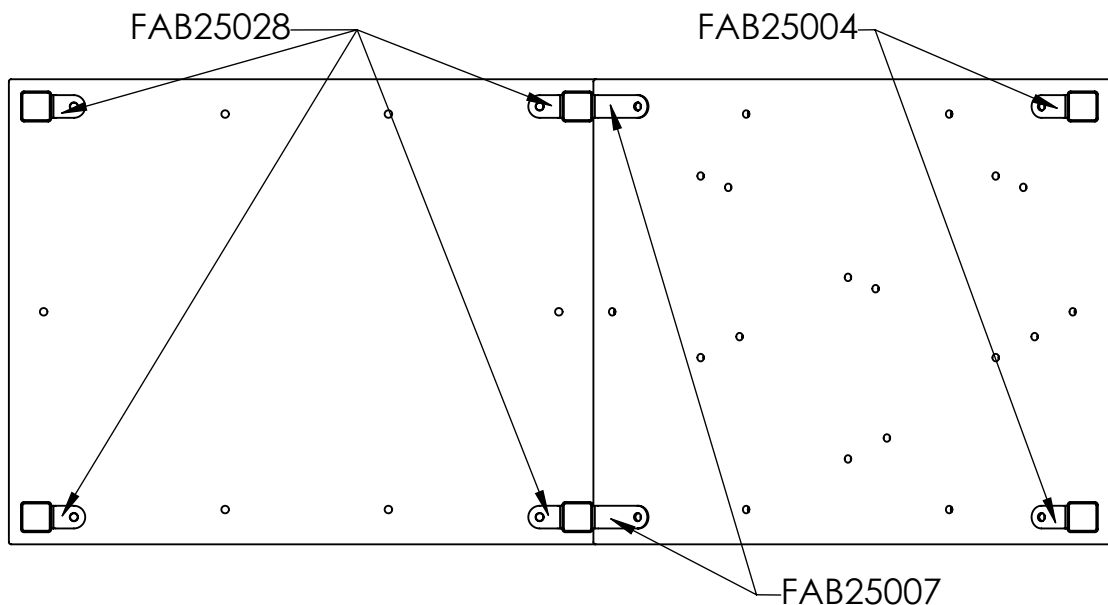

Note: All mentioned parts are fixed according to the assembly.  
 Obs: Alla angivna delar fästs enligt monteringsanvisningen.

**Assembly - 1. Platform**  
MONTERING - 1. PLATFORM  
BLFJ201B

**broa.**

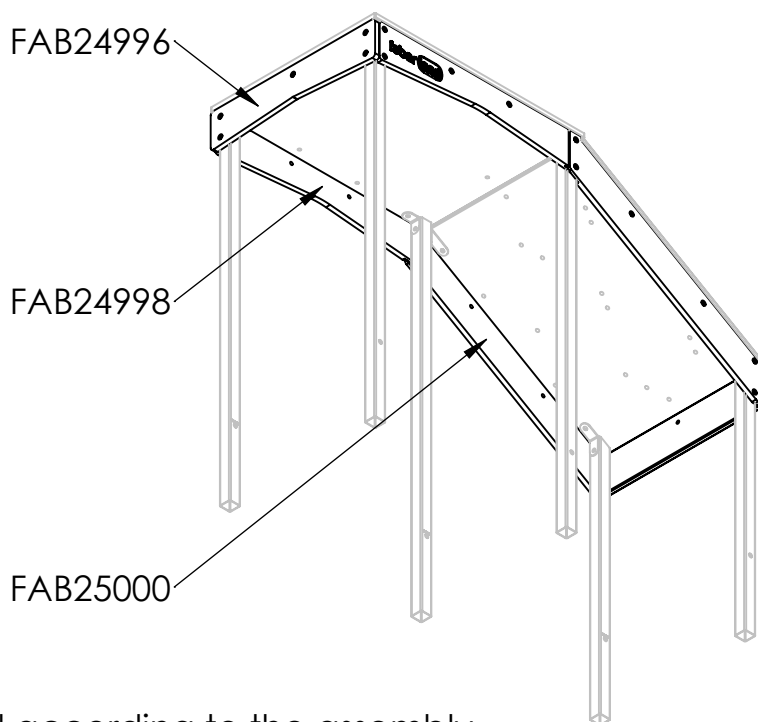
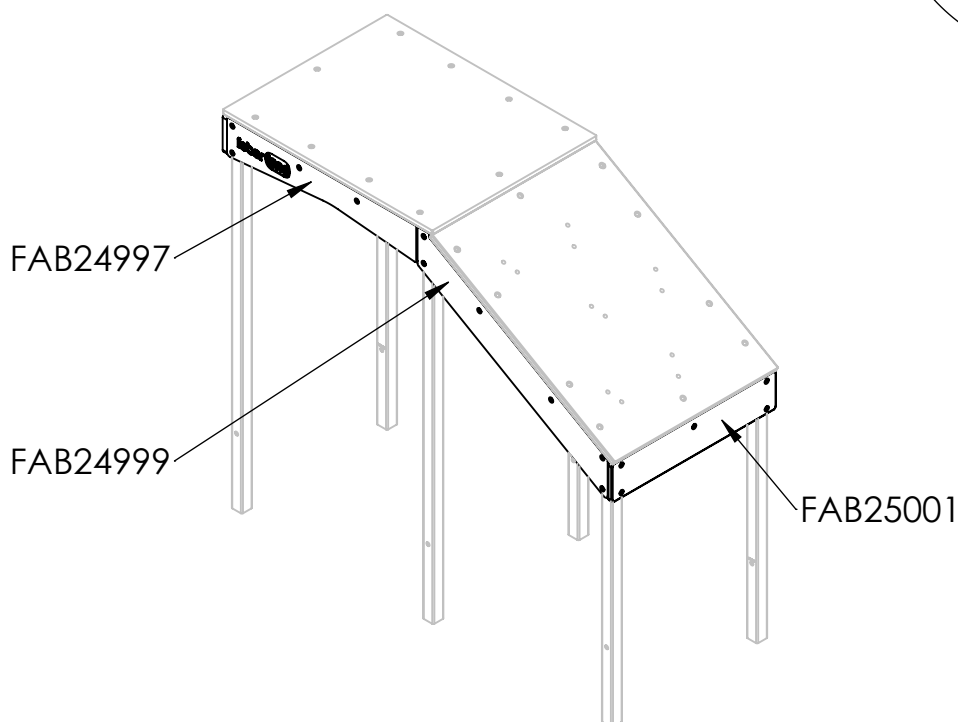
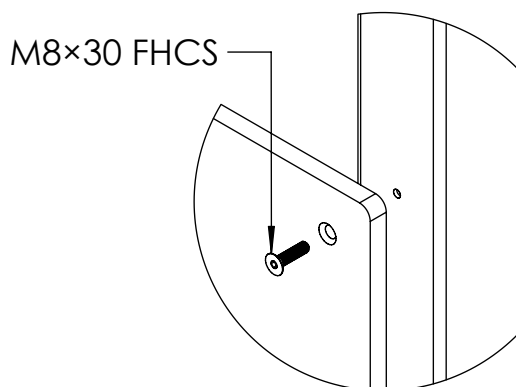

Note: All mentioned parts are fixed according to the assembly.  
Obs: Alla angivna delar fästs enligt monteringsanvisningen.

**Assembly - 1. Platform**  
MONTERING - 1. PLATFORM

BLFJ201B

**broa.**

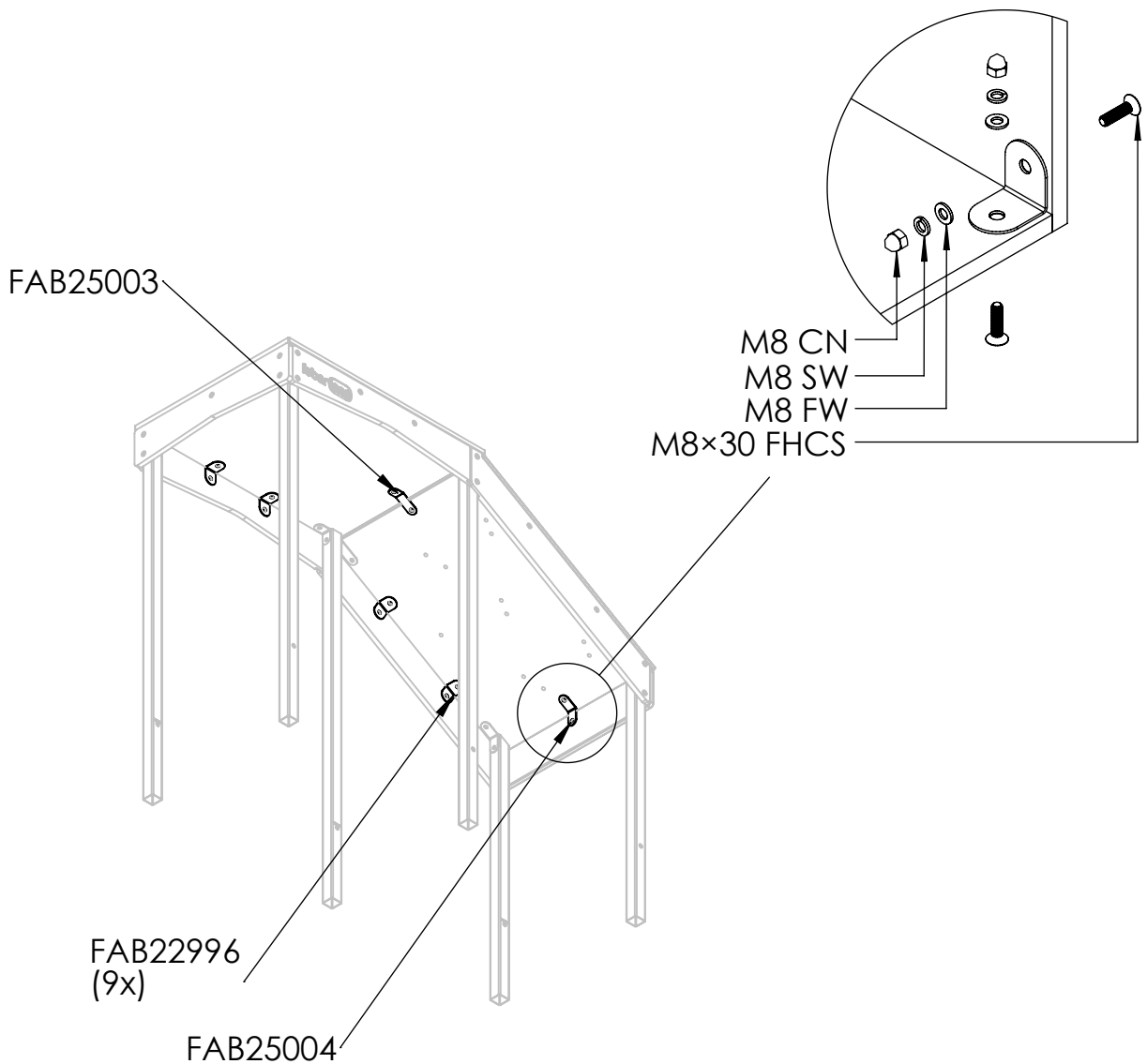
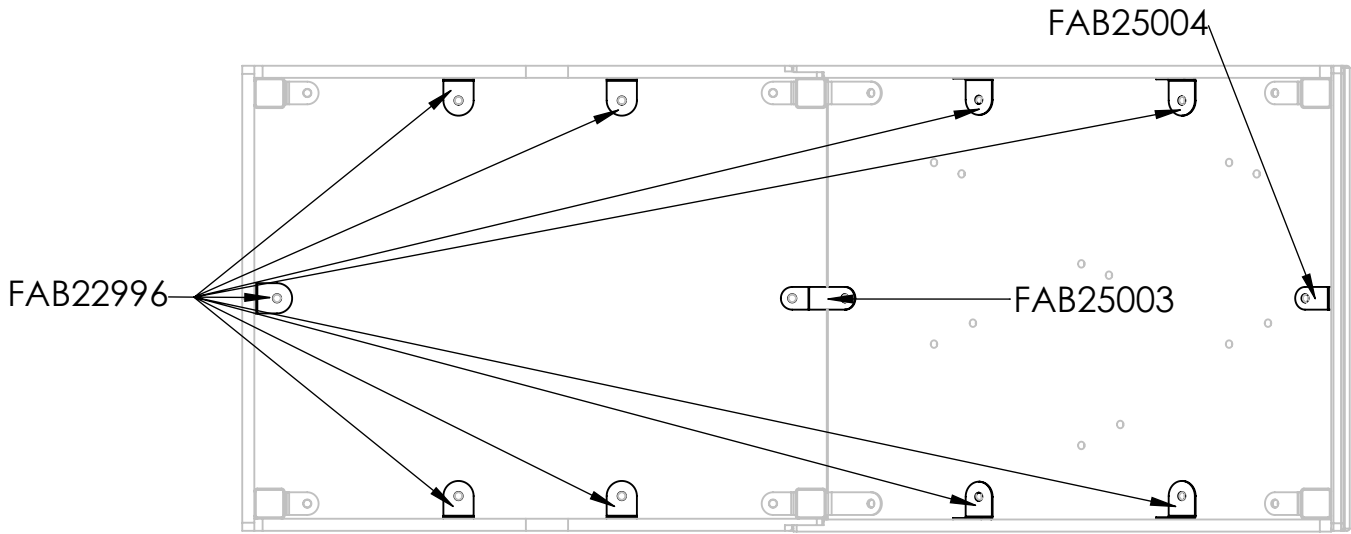

**Assembly - 1. Platform**  
MONTERING - 1. PLATFORM

BLFJ201B

**broa.**

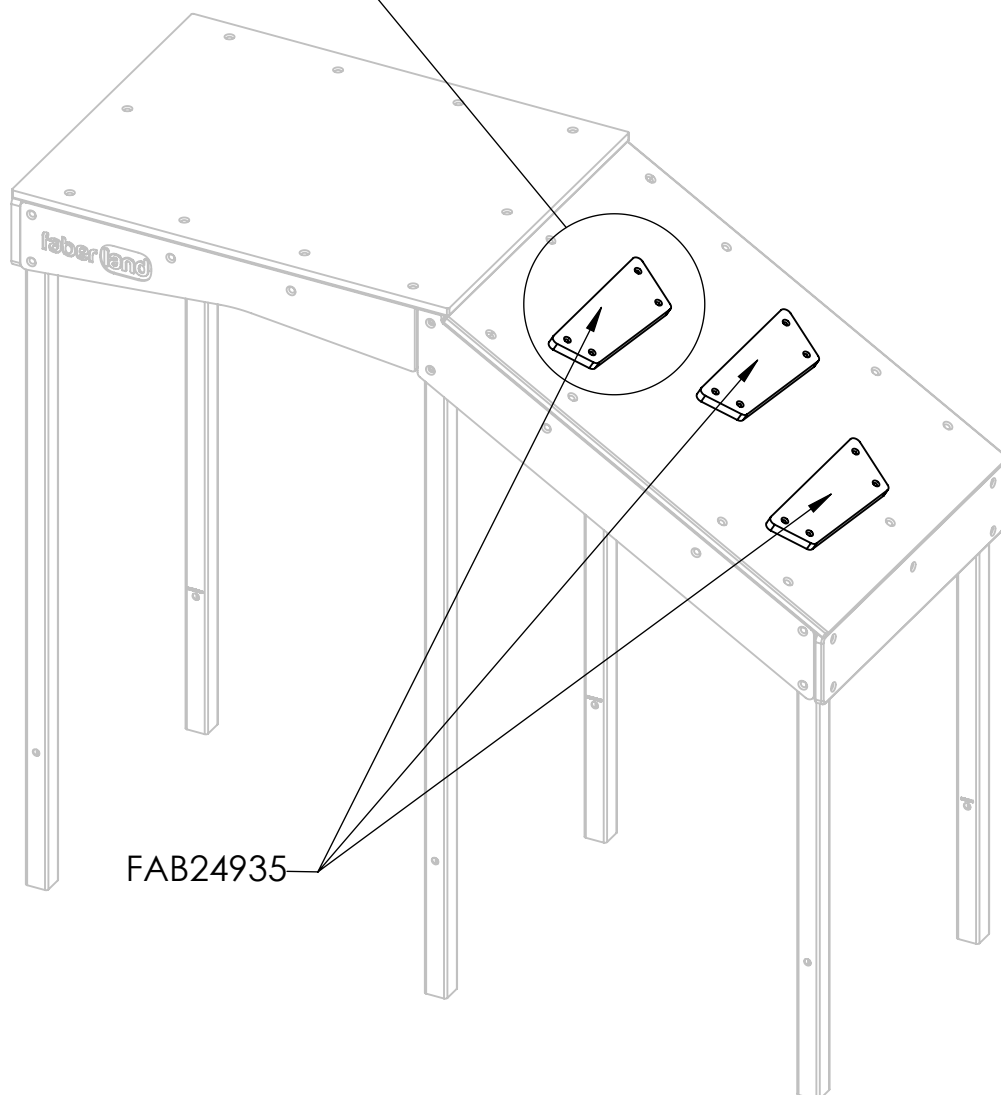
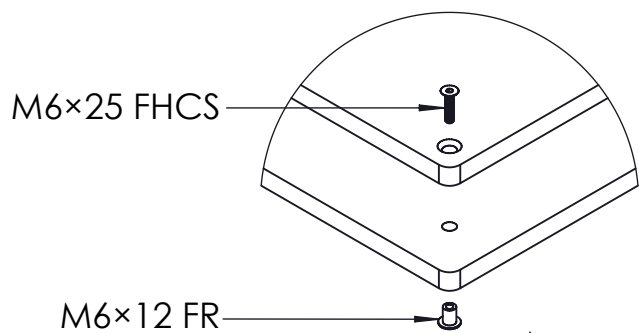

**Assembly - 2. Structure**  
**MONTERING – 2. KONSTRUKTION**

BLFJ201B

**broa.**

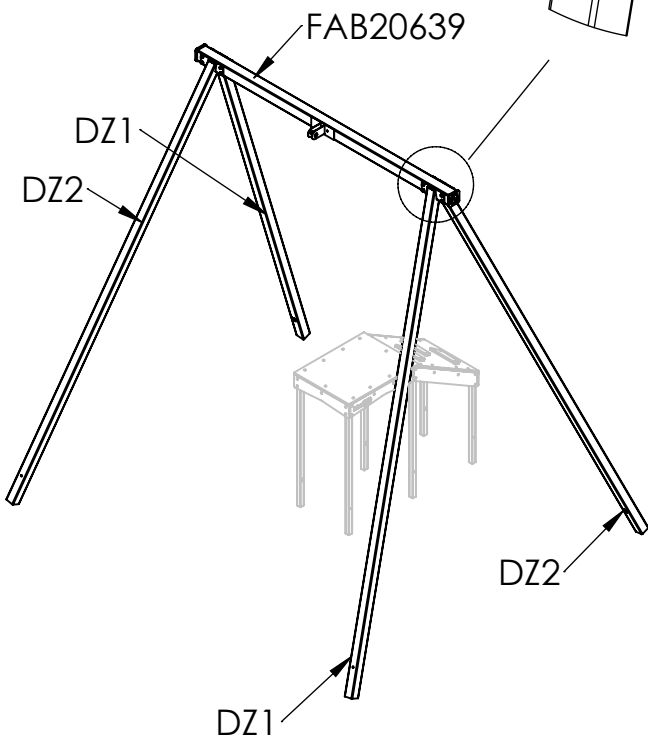
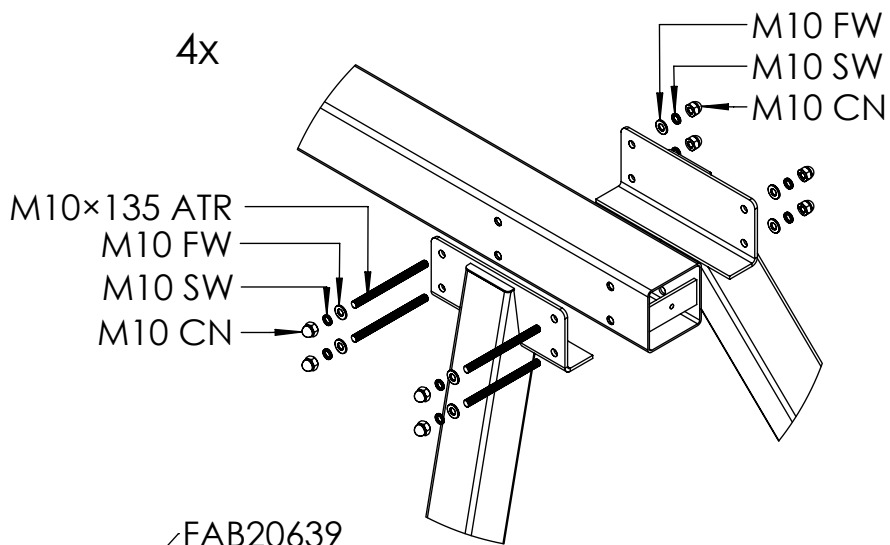
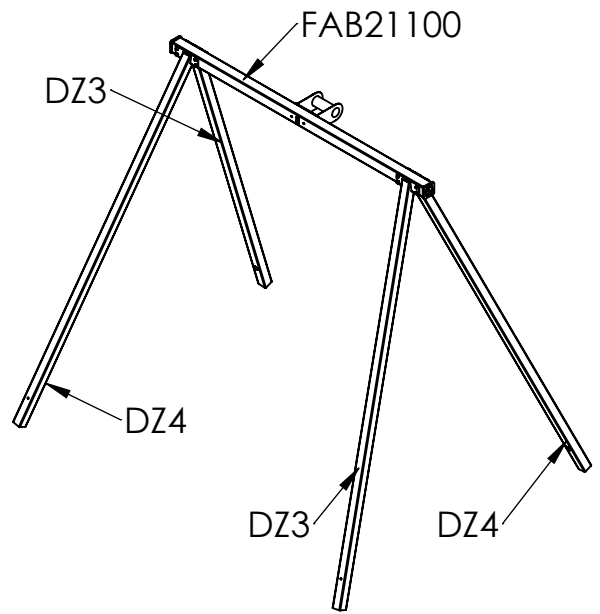

## Assembly - 3. Fittings MONTERING – 3. BESLAG

BLFJ201B

# broa.

1. Pull steel cable through FAB20639 swing beam and fix on cable holder with thimble/  
DRA STÅLKABELN GENOM FAB20639 GUNGBALK OCH FÄST DEN I KABELHÅLLAREN MED KAUS.

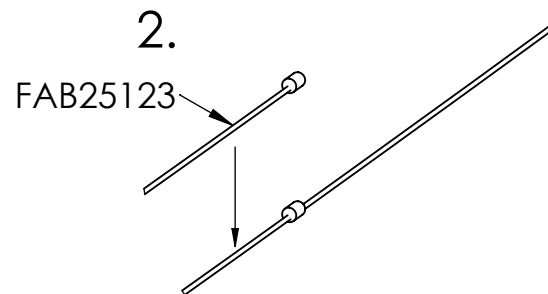
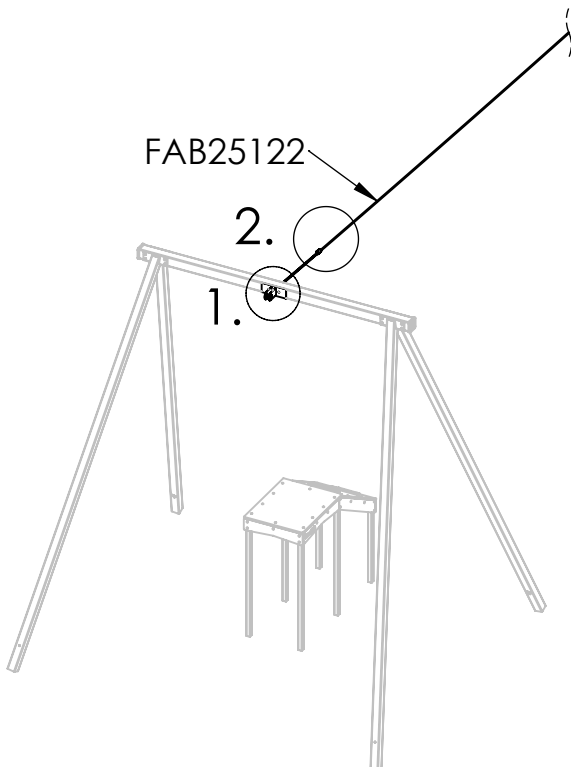
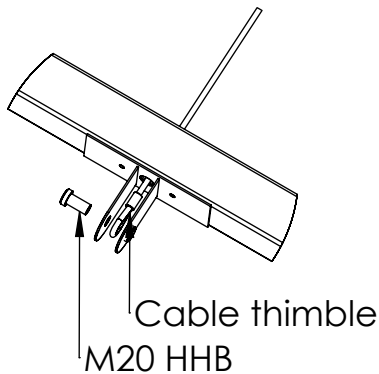
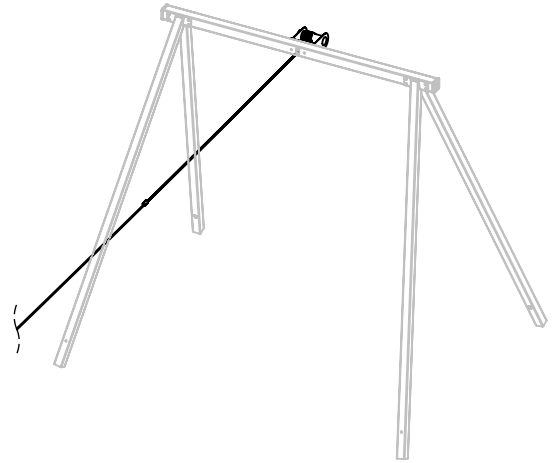

Cut FAB25123 spring to 1m before installation;  
Put it on steel cable for the starting section - Metal edge should be 100mm from FAB20639 beam/

KAPA FAB25123-FJÄDERN TILL 1 M FÖRE INSTALLATION.  
MONTERA DEN PÅ STÅLKABELN VID STARTSEKTIONEN.  
METALLKANTEN SKA VARA 100 MM FRÅN FAB20639-BALKEN.

Note: M20 HHB is preassembled on FAB20639 beam; cable thimble is on FAB21522 steel cable/

OBS: M20 HHB ÄR FÖRMONTERAD PÅ FAB20639-BALKEN; KABELKAUSEN SITTE PÅ STÅLKABELN FAB21522.

**Assembly - 3. Fittings**  
**MONTERING – 3. BESLAG**  
BLFJ201B

**broa.**

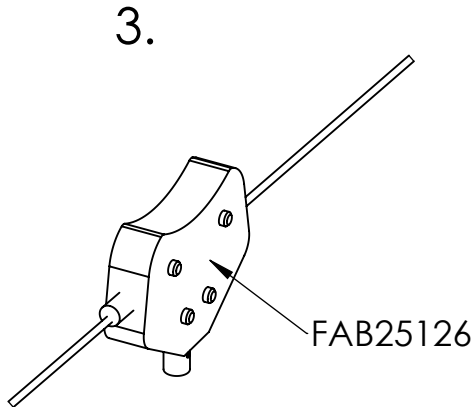

Install trolley on  
steel cable/  
MONTERA LÖPVAGNEN  
PÅ STÅLKABELN.

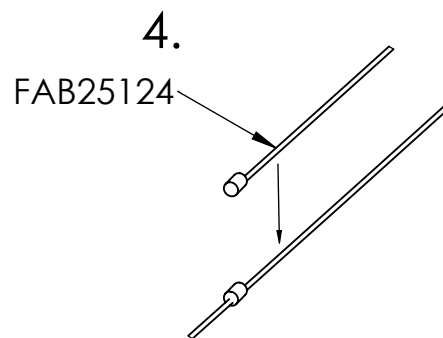
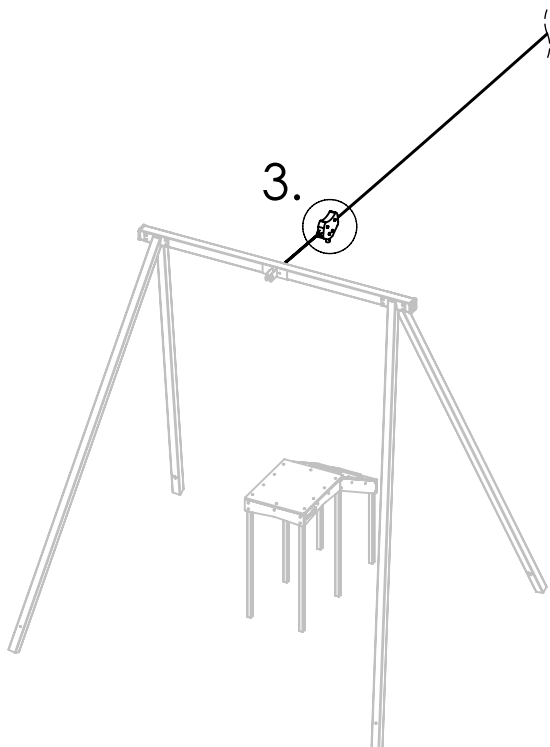
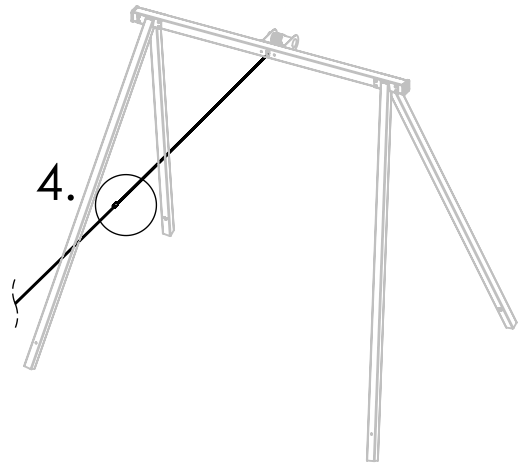

Install FAB25124 (3m brake spring)  
on steel cable for end section  
Metal edge should be 100 mm from  
FAB21100 beam/  
MONTERA FAB25124 (3 M BROMSFJÄDER)  
PÅ STÅLKABELN VID SLUTSEKTIONEN.  
METALLKANTEN SKA VARA  
100 MM FRÅN FAB21100-BALKEN

Note: Starting and end rubber spring should be against each other/  
OBS: START- OCH SLUTGUMMIFJÄDERN SKA MONTERAS MOT VARANDRA.

5.

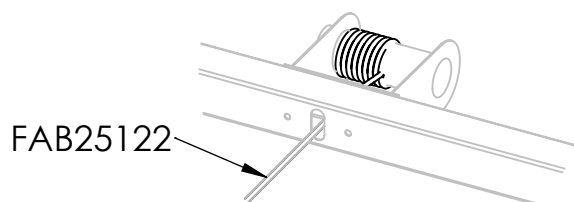

Roll steel cable  
on cable tensioning  
device/  
LINDA STÅLKABELN RUNT  
KABELSPÄNNAREN.

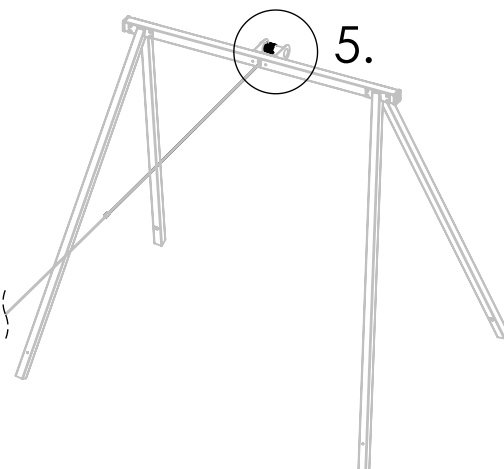

6.

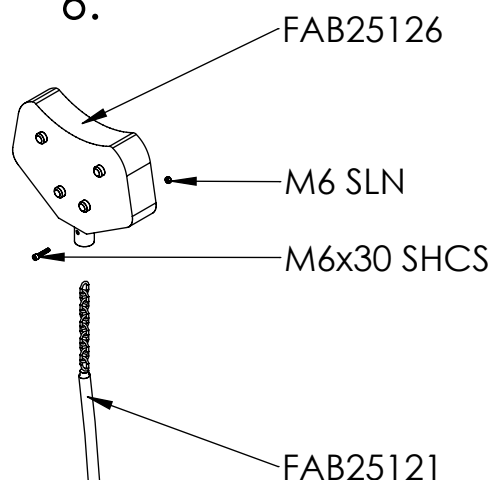

Install seat to trolley  
through chain/  
MONTERA SITSEN PÅ LÖPVAGNEN  
MED KEDJAN.

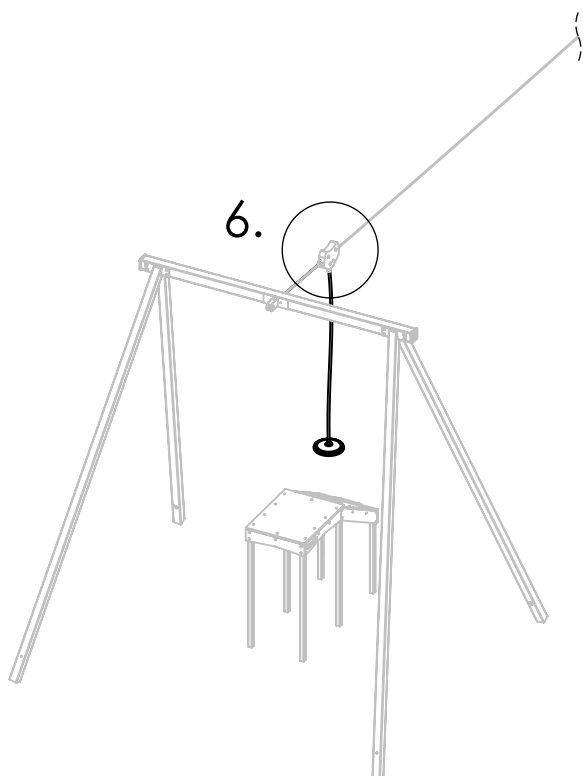

Note: M6x30 SHCS and M6 SLN are included in FAB25126 package/  
OBS: M6x30 SHCS OCH M6 SLN INGÅR I FÖRPACKNINGEN FAB25126.

**Assembly- 4.**  
MONTERING - 4.

BLFJ201B

**broa.**

