

## ASSEMBLY INSTRUCTIONS

## MONTERINGSANVISNINGAR

Fyrtorns Klätterborg

Four-towered climbing castle

BLFJ027

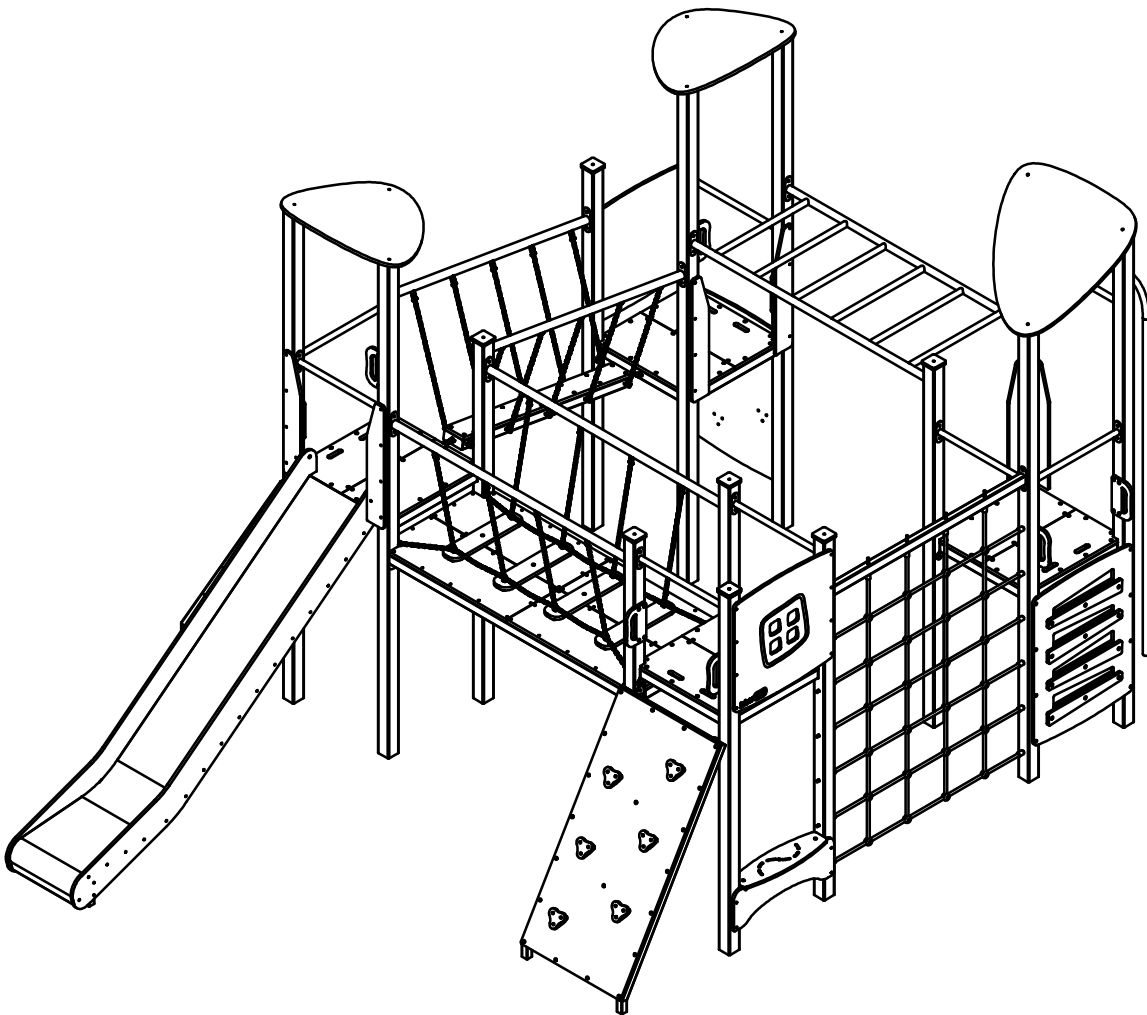

MANUFACTURER / TILLVERKARE:

Faberland Ltd./Kft.  
2119 Pécel, Pesti street 3.  
HUNGARY.

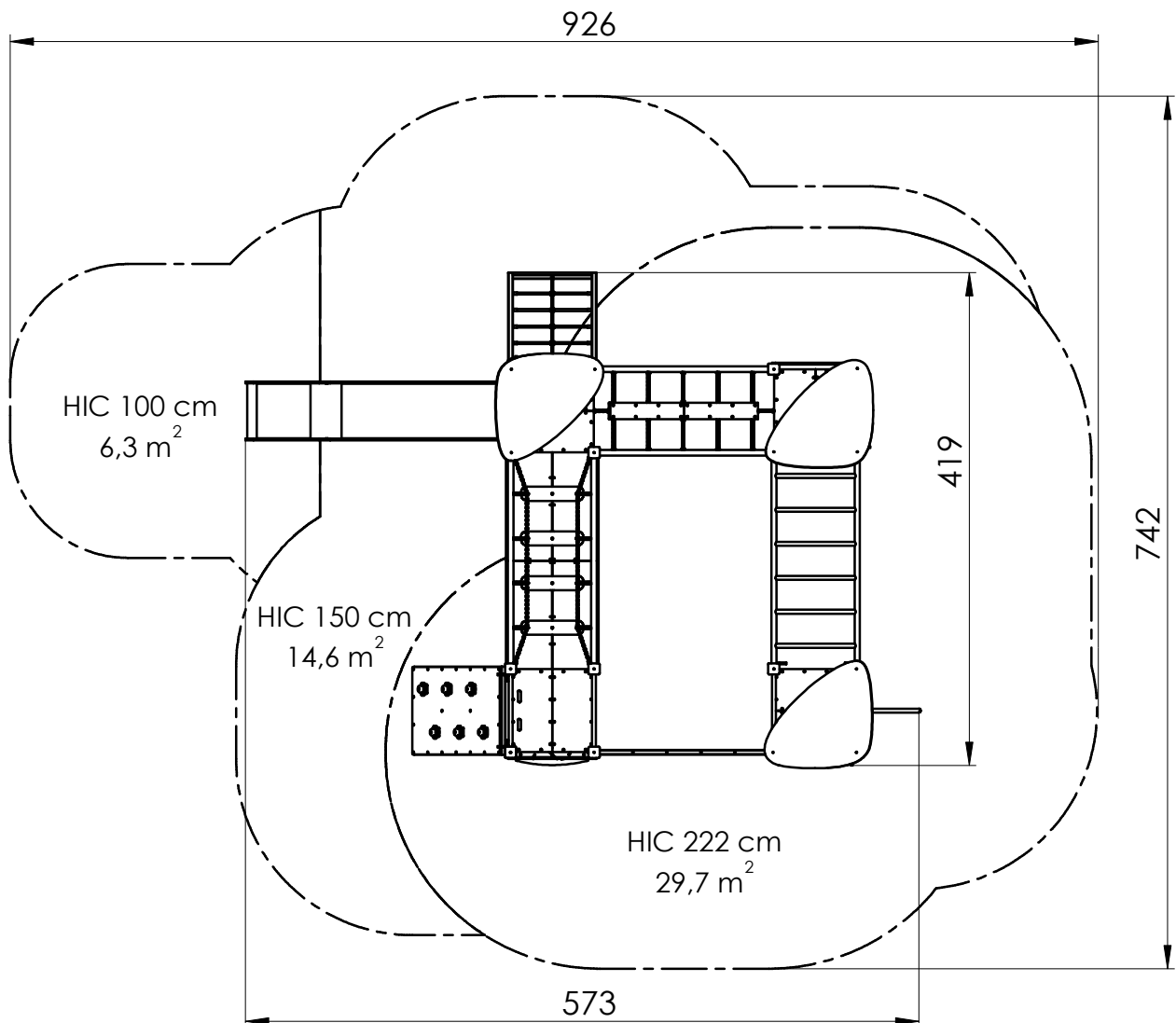
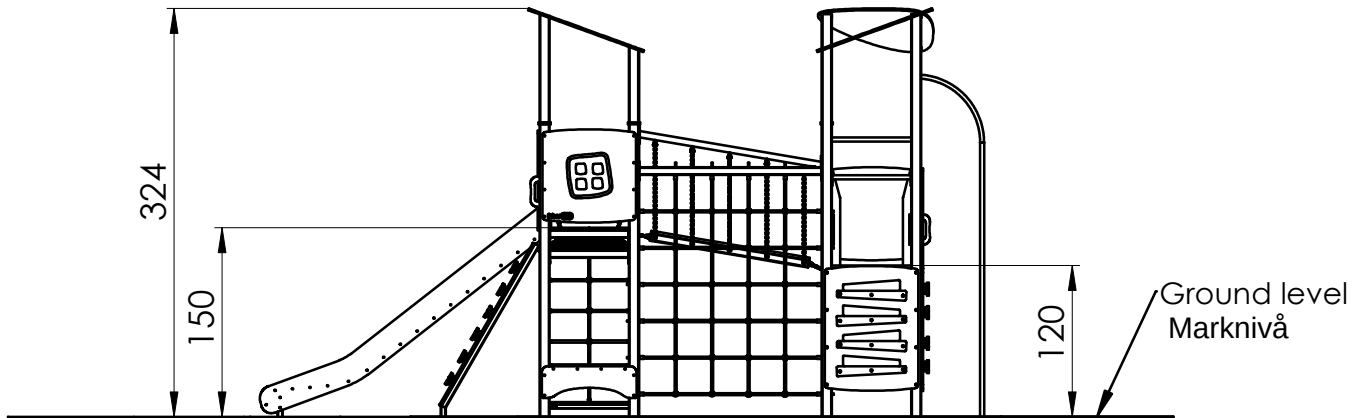

**FOOTING TYPES**  
**FUNDAMENTTYPER**

BLFJ027

**A**

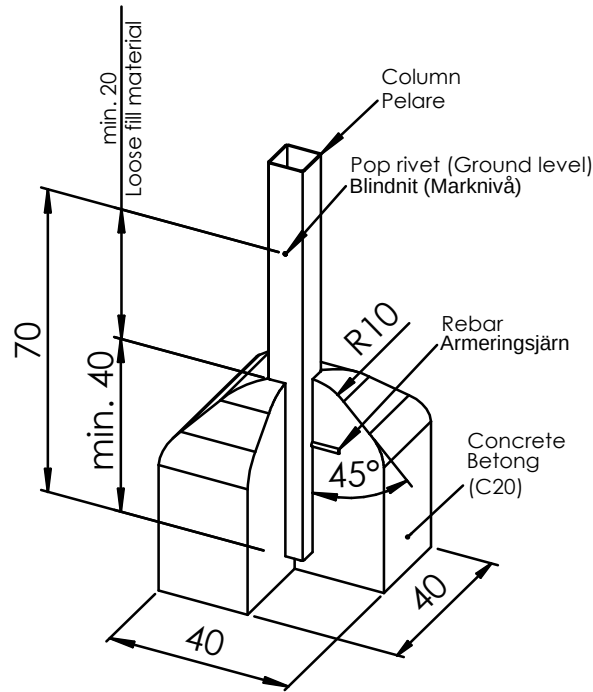

**B**

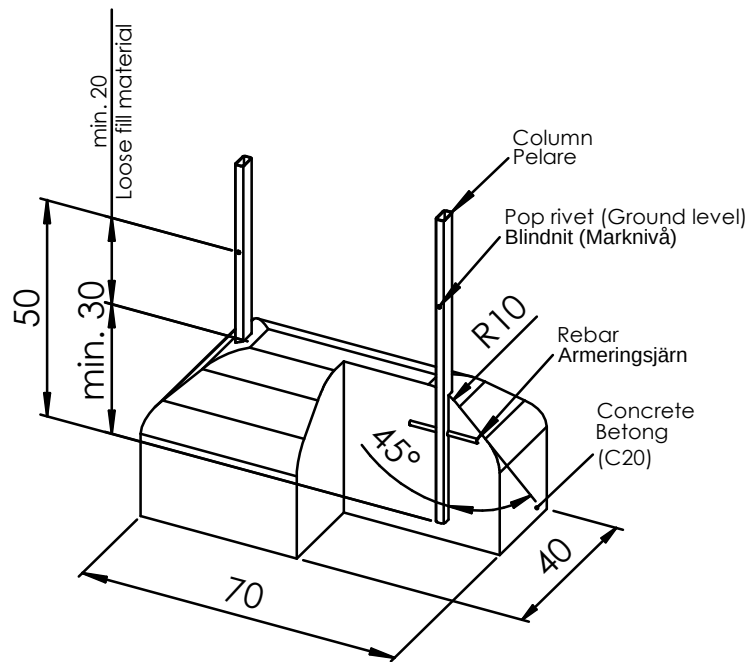

Leveling at 50 cm and 70 cm below ground  
AVJ MNING P  50 CM UNDER MARKNIV 

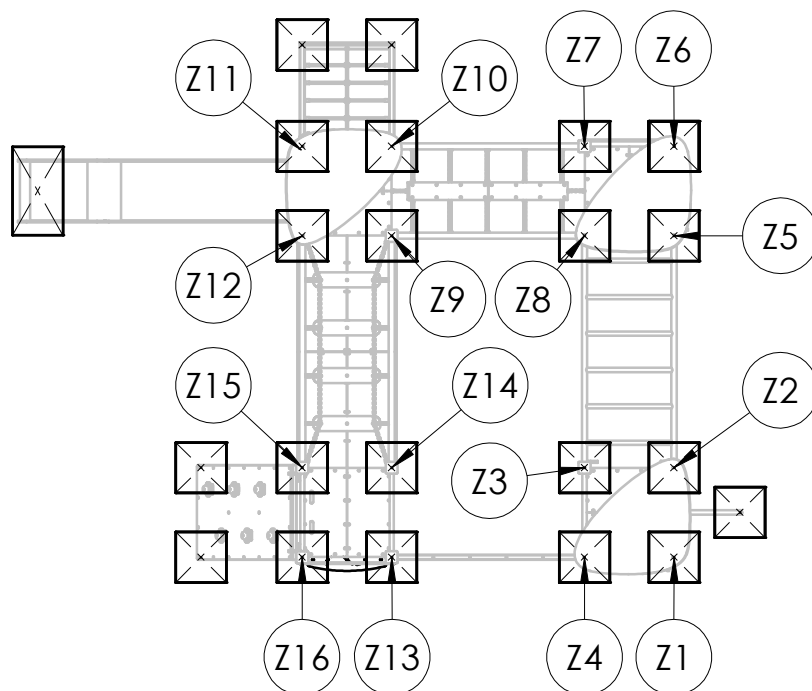
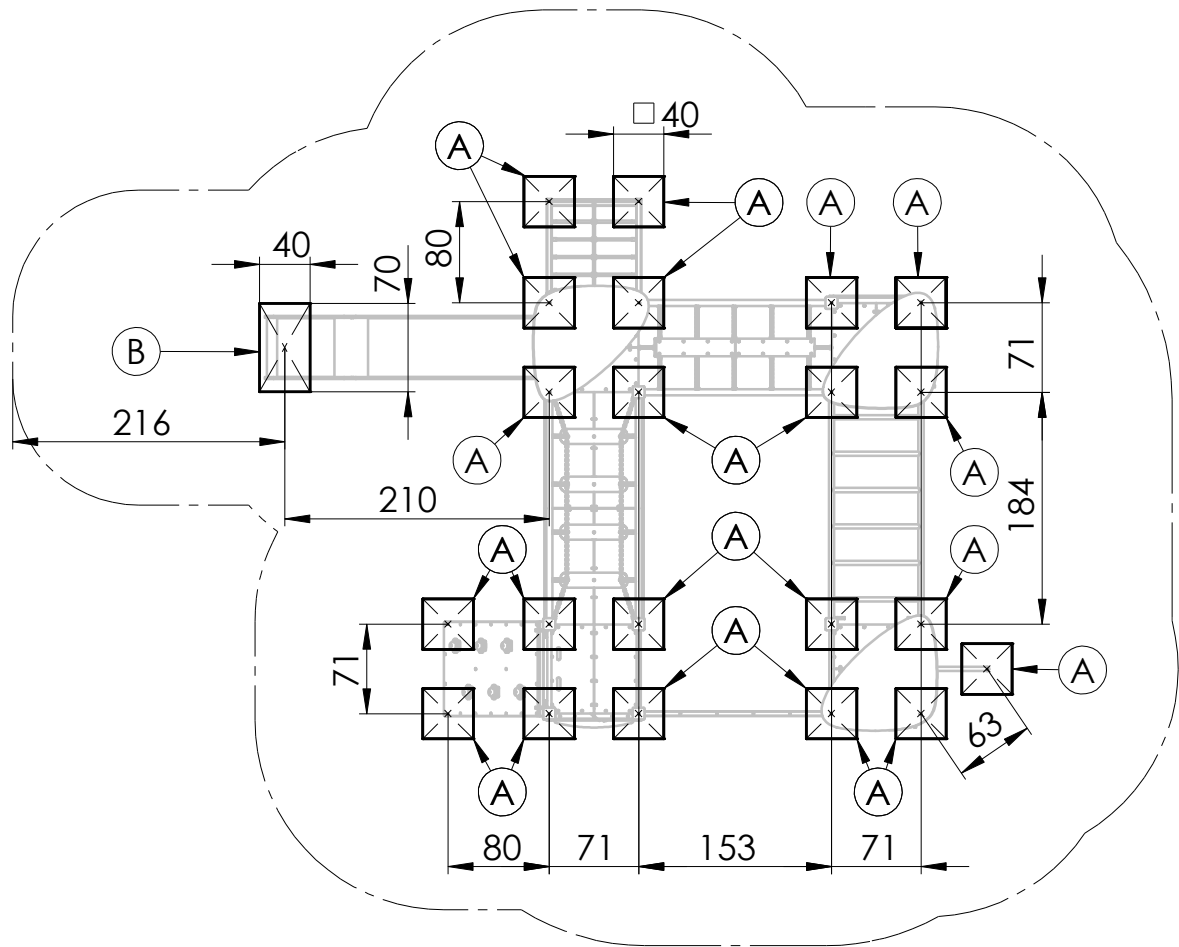

**FOOTING PLAN**  
**FUNDAMENTPLAN / GRUNDLÄGGNING**

BLFJ027

**broa.**

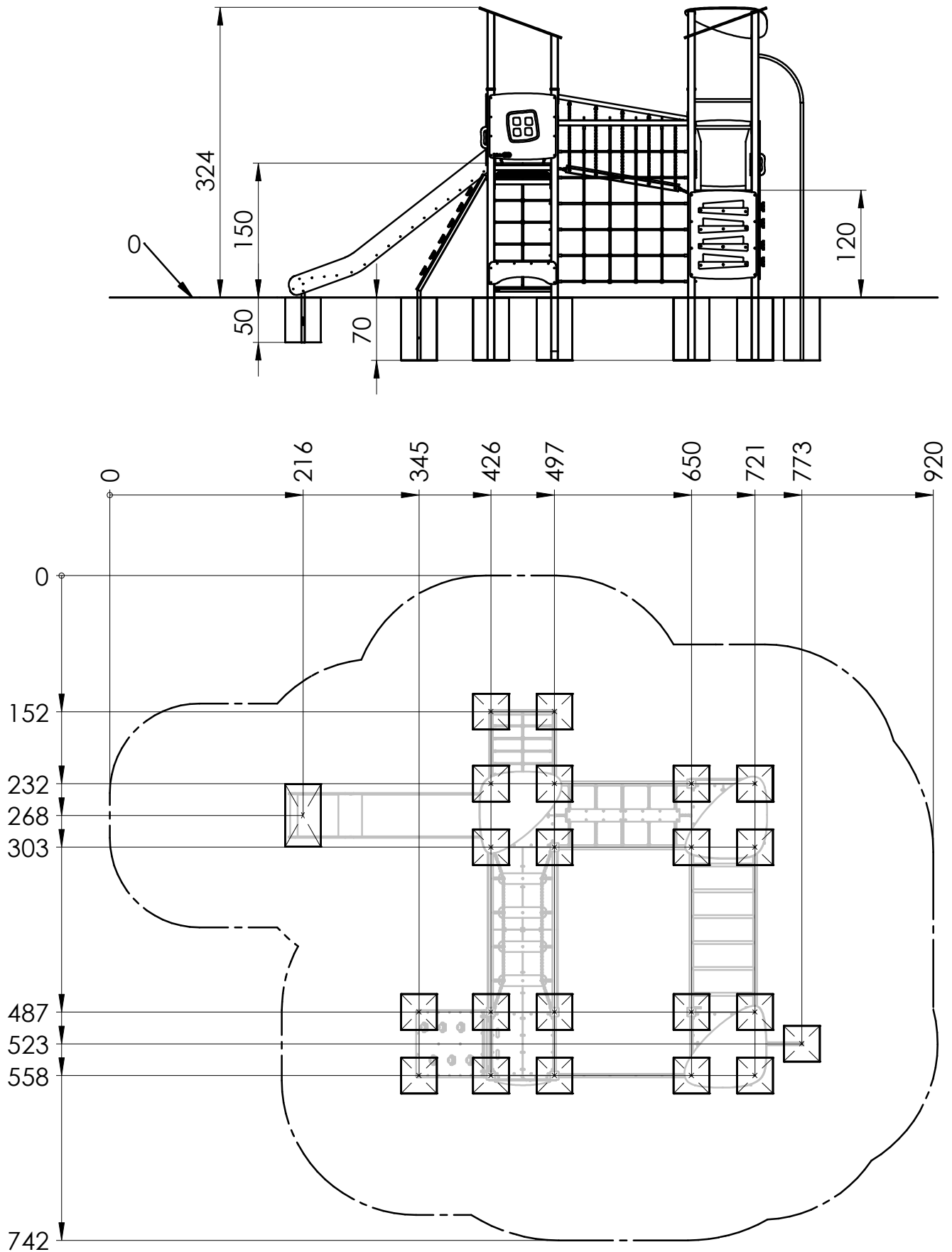

**BILL OF MATERIALS**  
**MATERIALFÖRTECKNING**

BLFJ027

**broa.**

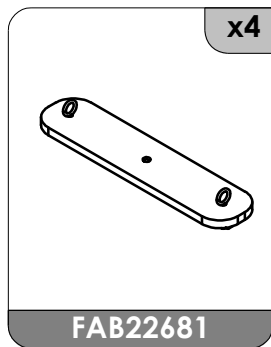
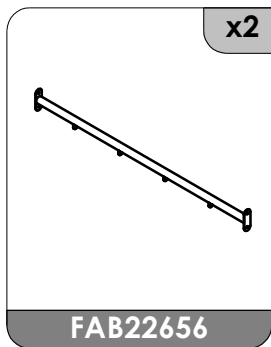
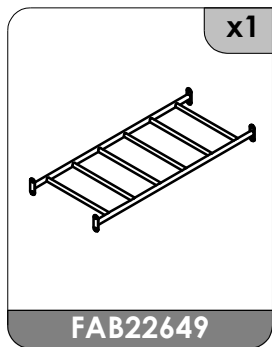
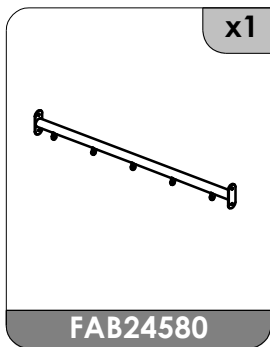
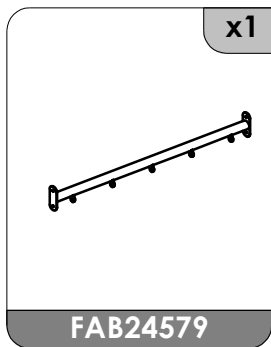
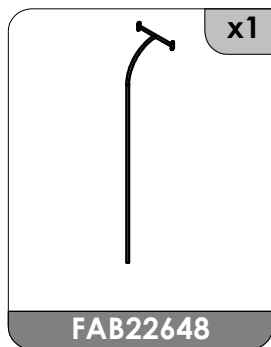
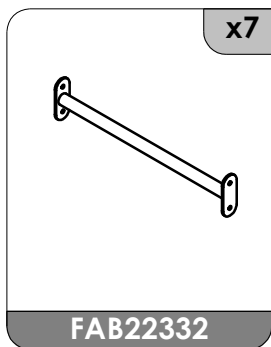
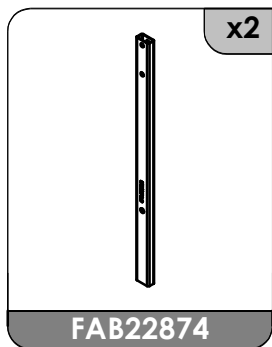
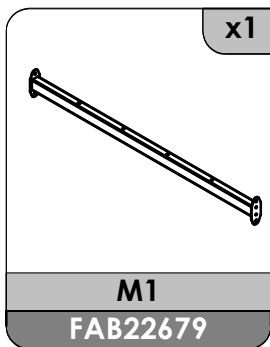
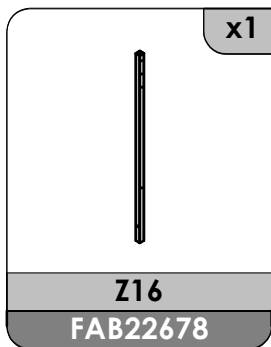
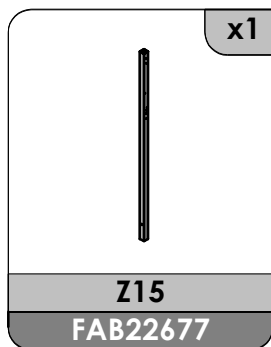
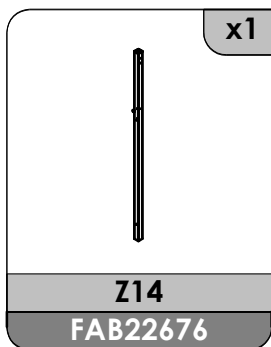
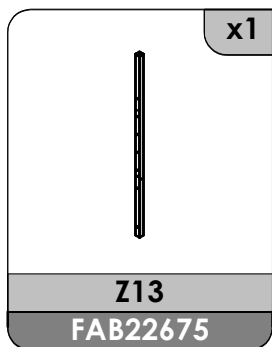
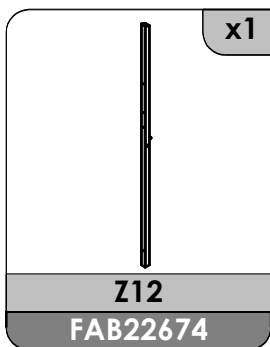
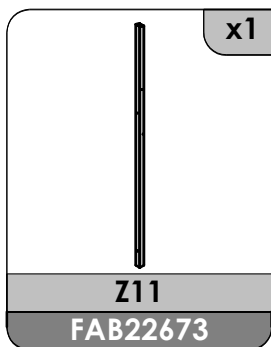
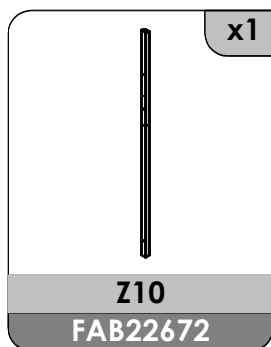
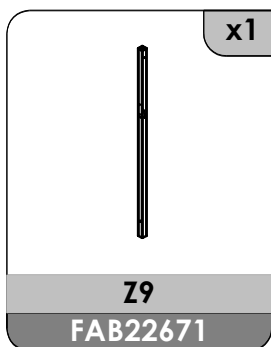
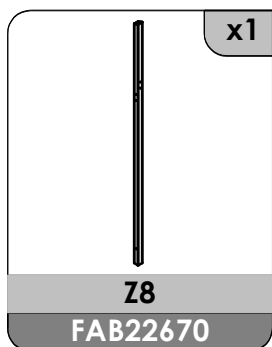
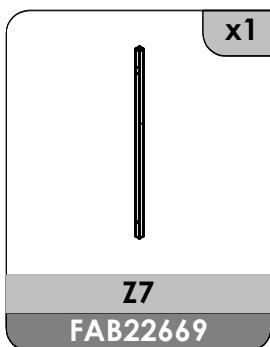
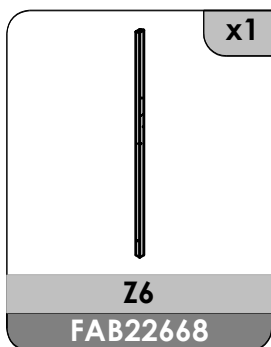
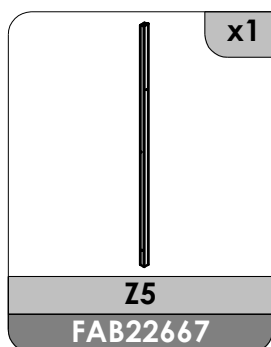
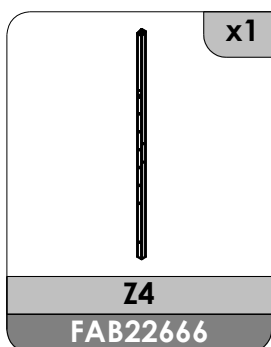
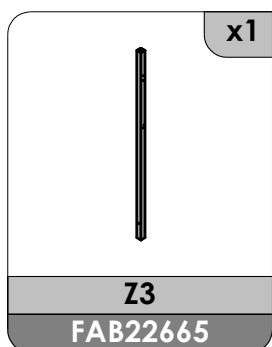
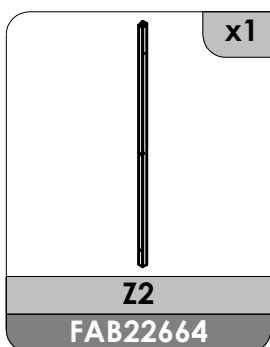
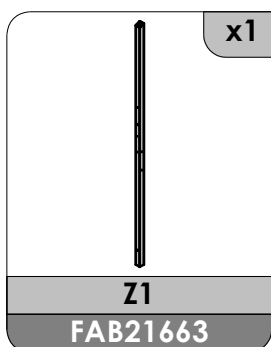

**BILL OF MATERIALS**  
**MATERIALFÖRTECKNING**

BLFJ027

**broa.**

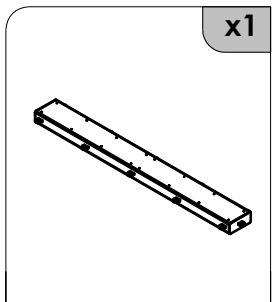
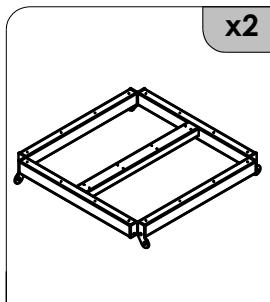
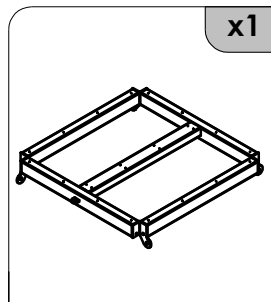
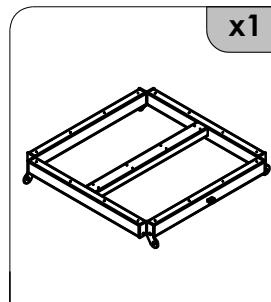
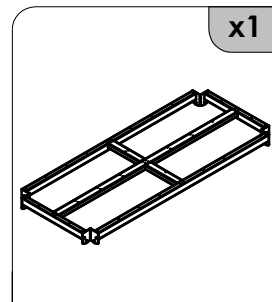
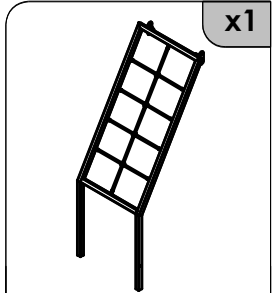
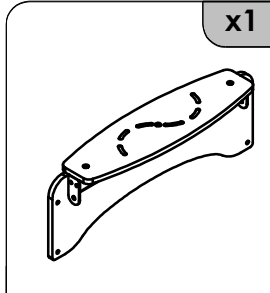
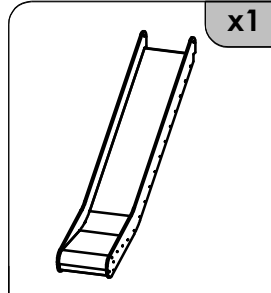
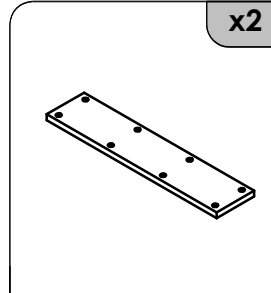
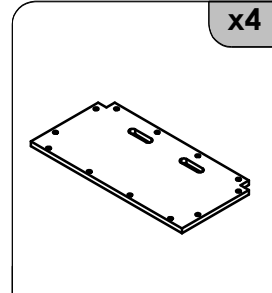
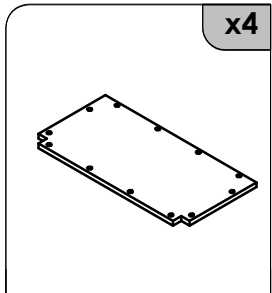
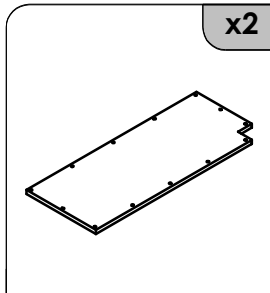
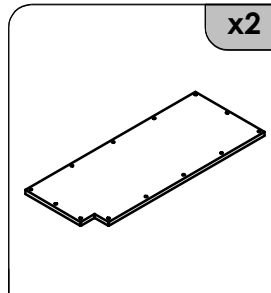
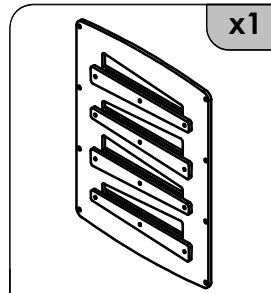
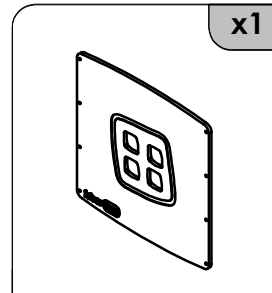
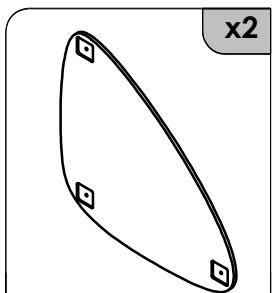
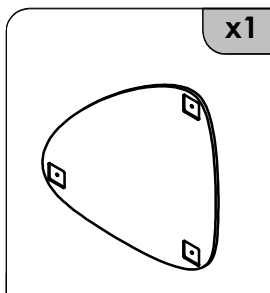
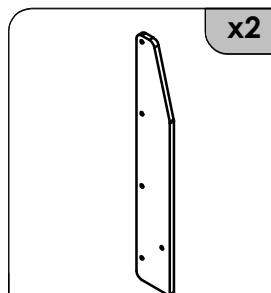
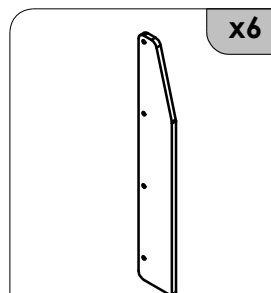
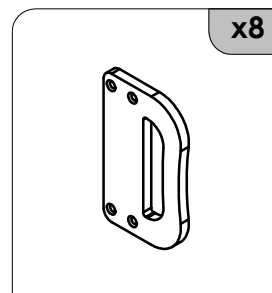
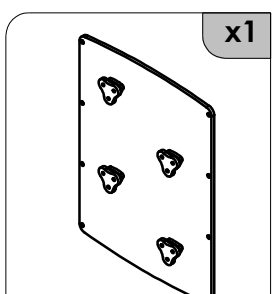
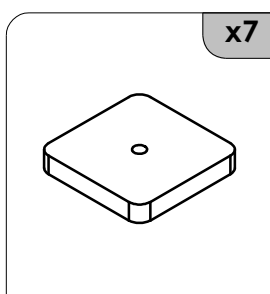
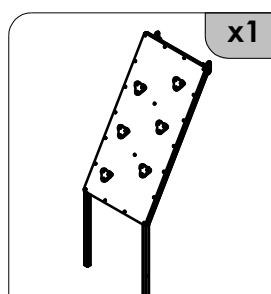
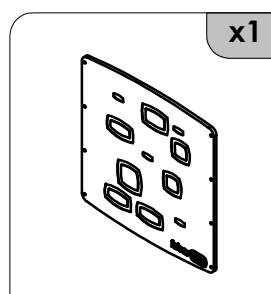
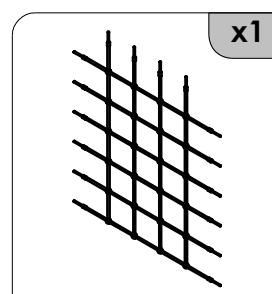
 FAB22682 x1	 FAB22333 x2	 FAB22684 x1	 FAB22685 x1	 FAB22686 x1
 FAB22652 x1	 FAB22680 x1	 FLFJ031/FLFJ032 x1	 FAB22723 x2	 FAB21017 x4
 FAB21018 x4	 FAB22720 x2	 FAB22719 x2	 FAB22328 x1	 FAB22714 x1
 FAB24960 x2	 FAB22709 x1	 FAB24568 x2	 FAB22711 x6	 FAB22327 x8
 FAB22718 x1	 FAB22230 x7	 FAB22653 x1	 FAB22717 x1	 FAB22605 x1

**BILL OF MATERIALS**  
**MATERIALFÖRTECKNING**  
 BLFJ027

 <p>x22</p> <p>D10 Rebar</p>	 <p>x161</p> <p>M8x30 FHCS</p>	 <p>x175</p> <p>M8x30 BHCS</p>	 <p>x4</p> <p>M8 CN</p>	 <p>x187</p> <p>M8 SW</p>
 <p>x104</p> <p>M8 FW</p>	 <p>x16</p> <p>M10 SLN</p>	 <p>x4</p> <p>M8 SLN</p>	 <p>x2</p> <p>M6x30 FHCS</p>	 <p>x16</p> <p>M10 FW</p>
 <p>x44</p> <p>SHK 6mm</p>	 <p>x10</p> <p>Chain 76cm</p>	 <p>x2</p> <p>Chain 8cm</p>	 <p>x8</p> <p>Chain 60cm</p>	 <p>x2</p> <p>Chain 1,8m</p>
 <p>x36</p> <p>Chain plug-1 Chain plug-2</p> <p>Chain plug</p>	 <p>x2</p> <p>FAB24526</p>	 <p>x4</p> <p>M8x45 BHCS</p>	 <p>x16</p> <p>Cap-2 Cap-1</p> <p>Cap 32</p>	 <p>x1</p> <p>Product label</p>

**ASSEMBLY - 1. PLATFORM**  
**MONTERING – 1. PLATTFORM**

BLFJ027

**broa.**

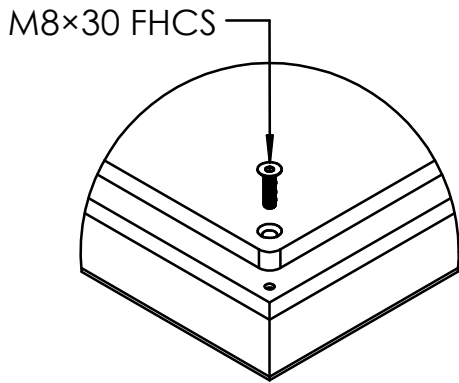

①. x2

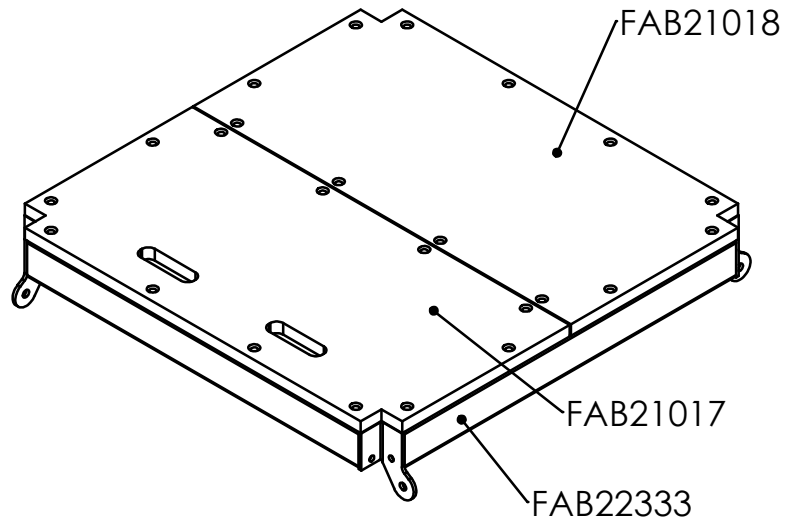

②. x1

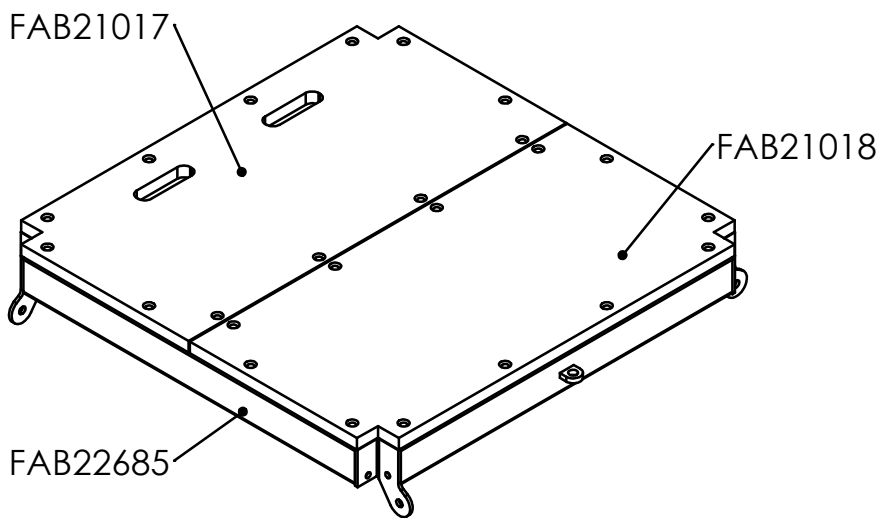

③. x1

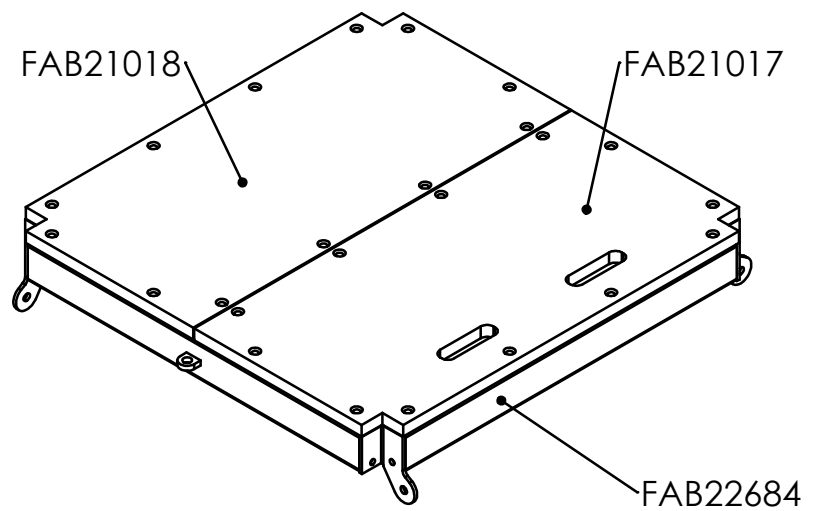

**ASSEMBLY - 1. PLATFORM**  
**MONTERING – 1. PLATTFORM**  
BLFJ027

M8×30 FHCS

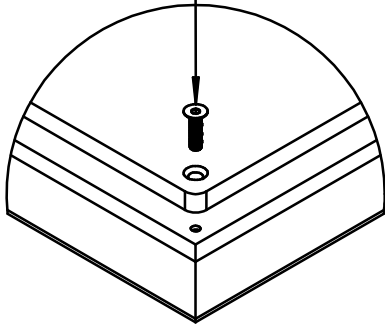

④. x1

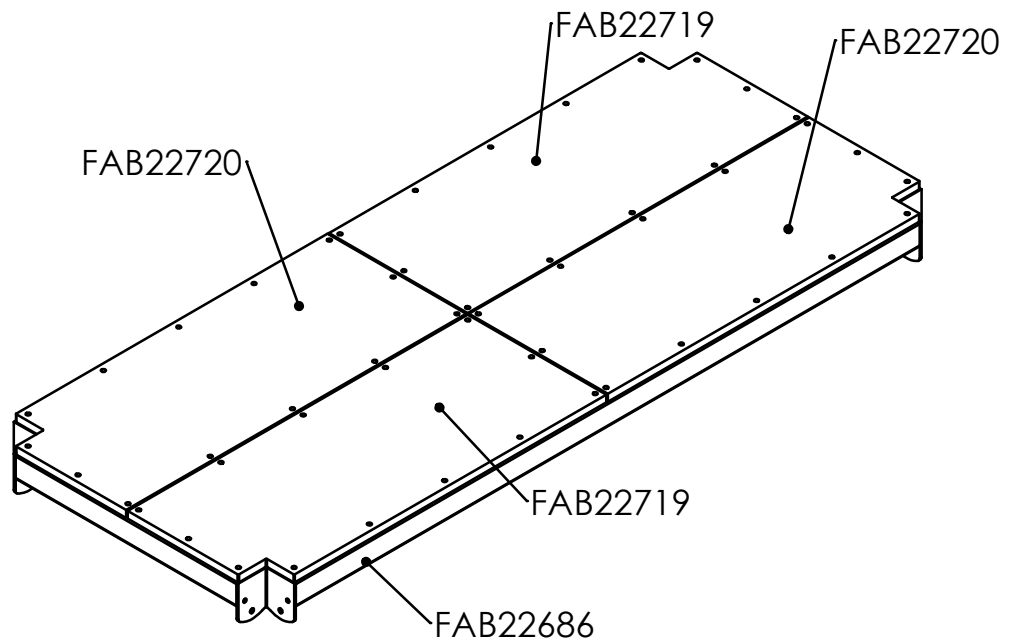

⑤. x1

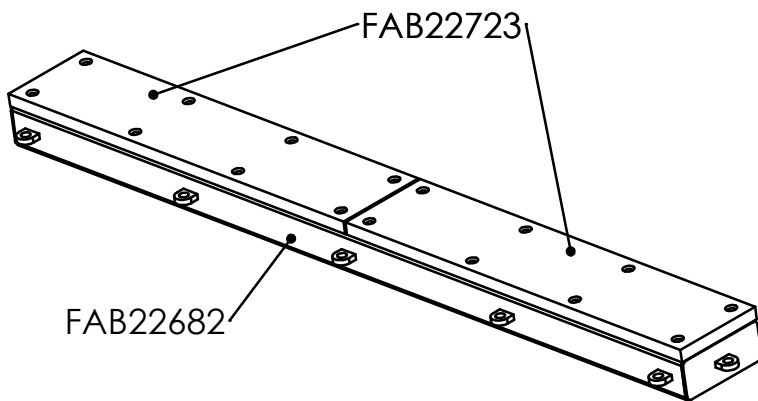

**ASSEMBLY - 2. STRUCTURE**  
**MONTERING – 2. KONSTRUKTION**

BLFJ027

**broa.**

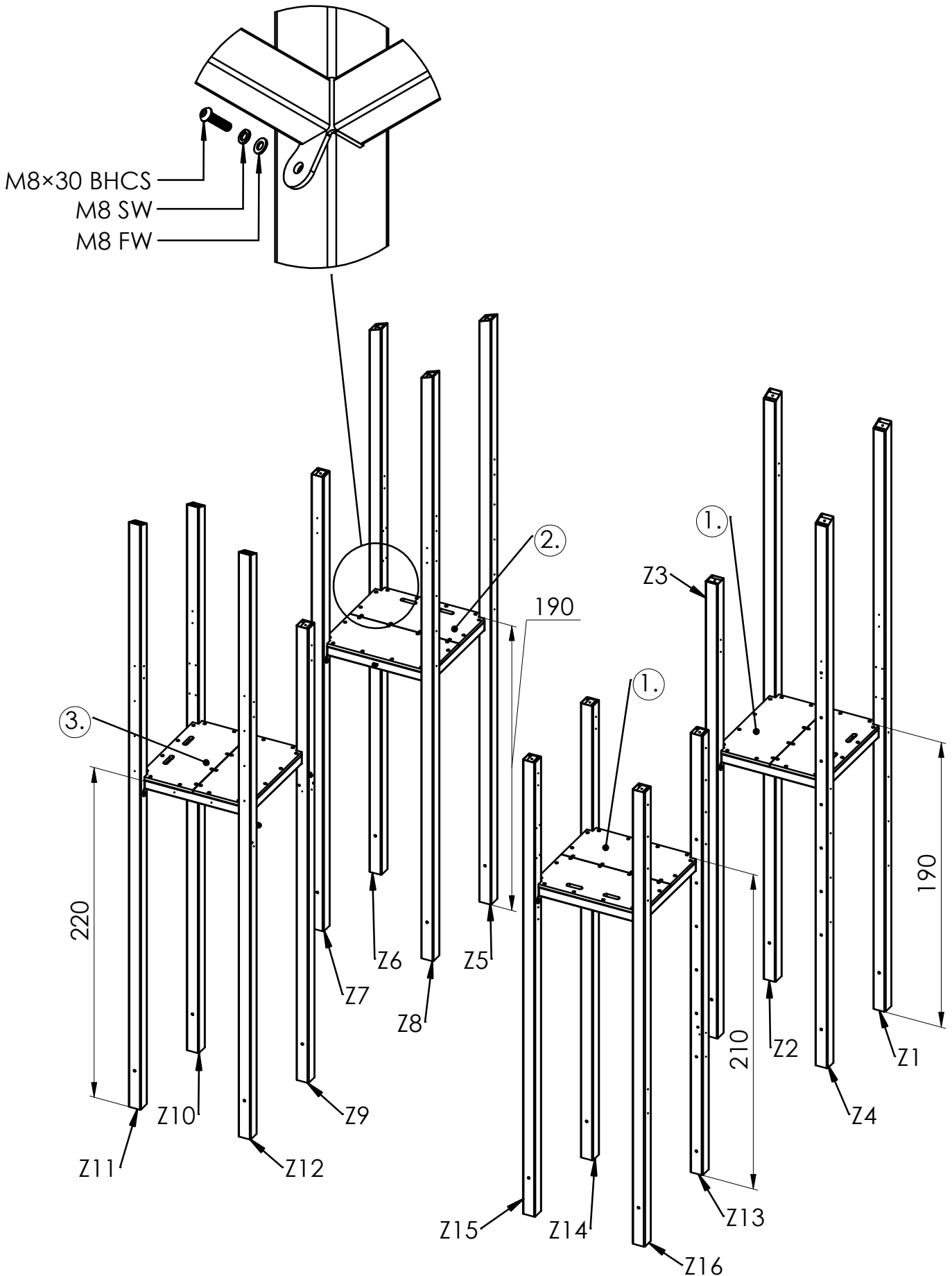

**ASSEMBLY - 2. STRUCTURE**  
**MONTERING – 2. KONSTRUKTION**

BLFJ027

**broa.**

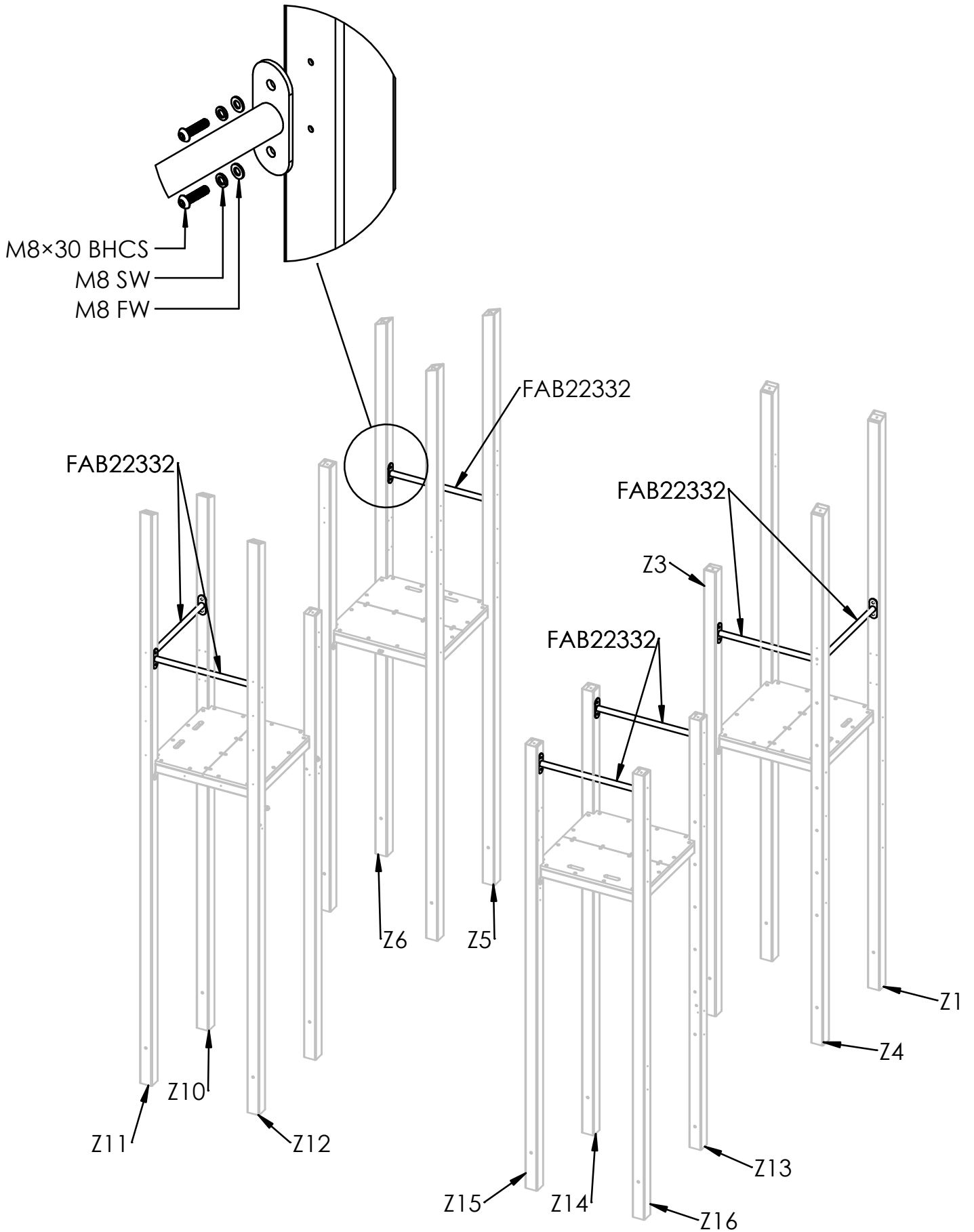

**ASSEMBLY - 2. STRUCTURE**  
**MONTERING – 2. KONSTRUKTION**  
BLFJ027

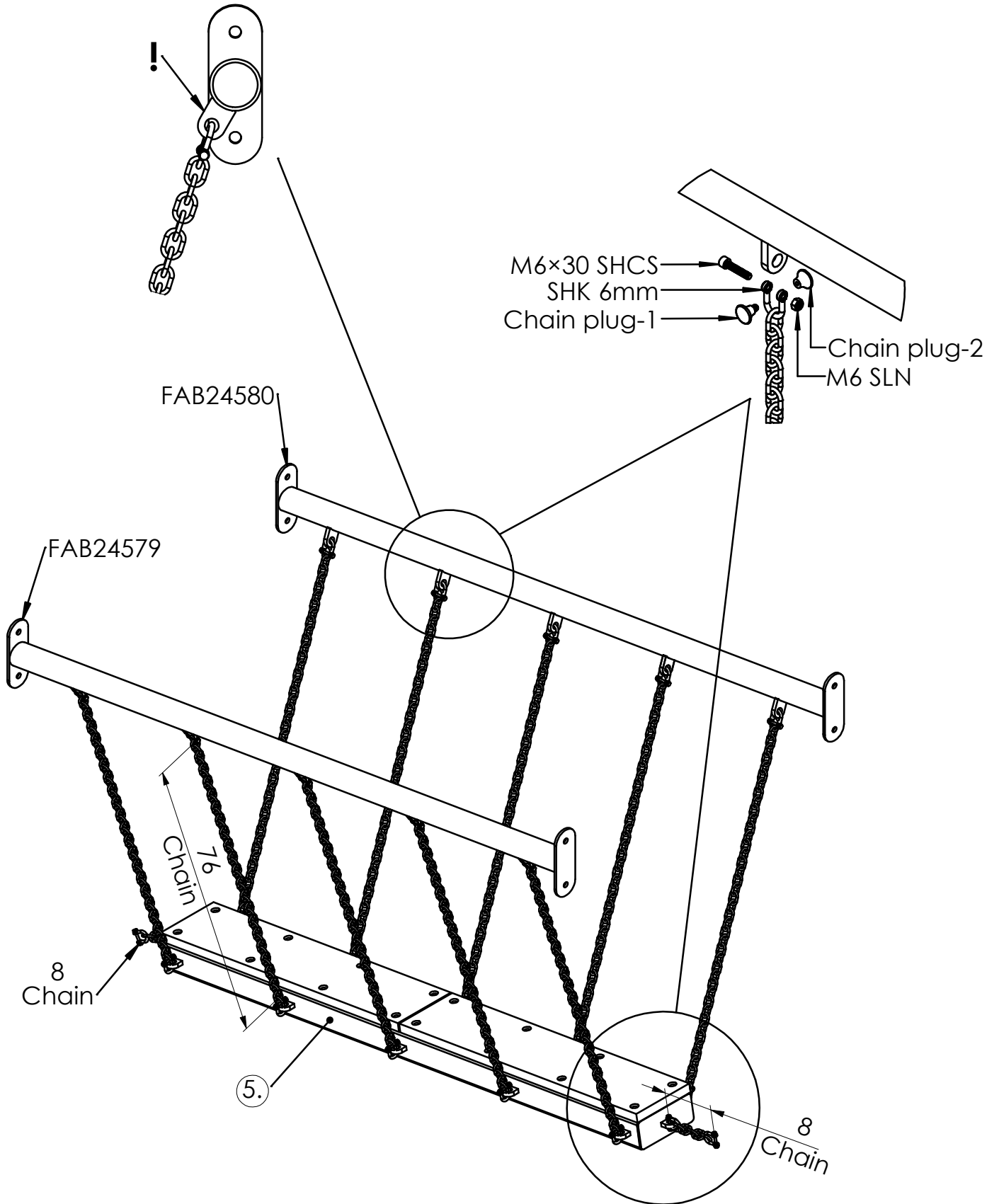

**ASSEMBLY - 2. STRUCTURE**  
**MONTERING – 2. KONSTRUKTION**  
 BLFJ027

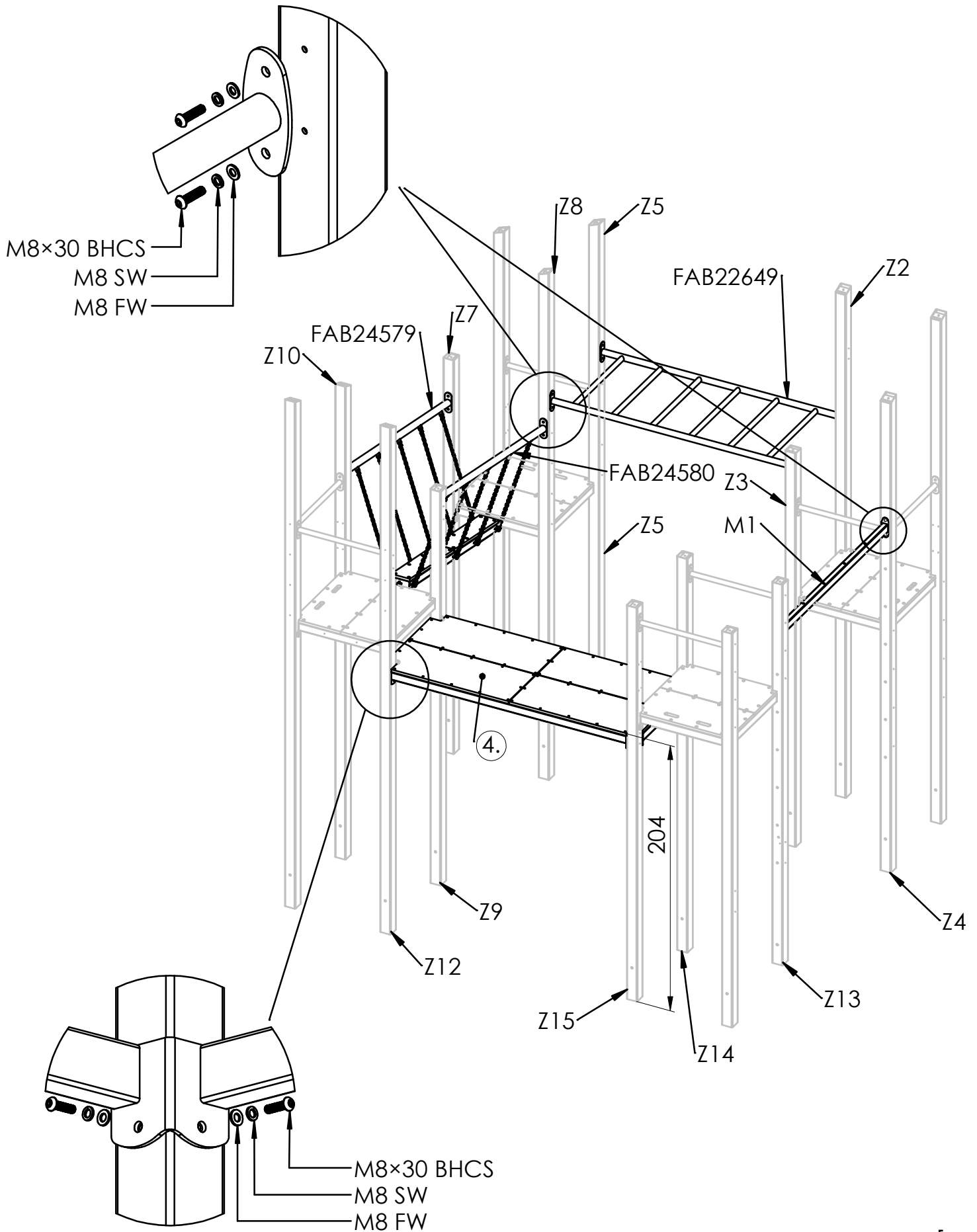

**ASSEMBLY - 2. STRUCTURE**  
**MONTERING – 2. KONSTRUKTION**  
BLFJ027

**broa.**

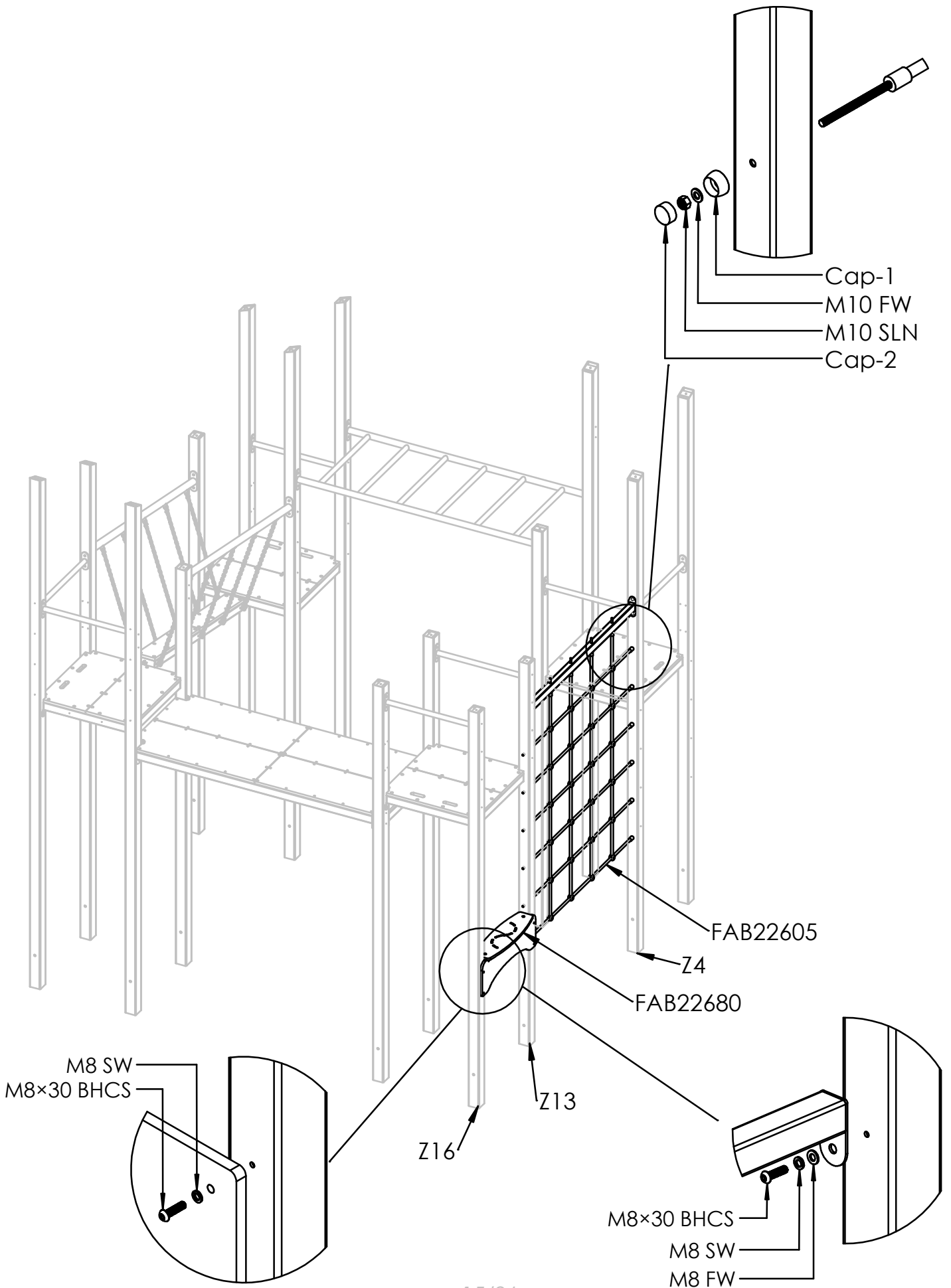

**ASSEMBLY - 2. STRUCTURE**  
**MONTERING – 2. KONSTRUKTION**  
 BLFJ027

**broa.**

M8×30 FHCS

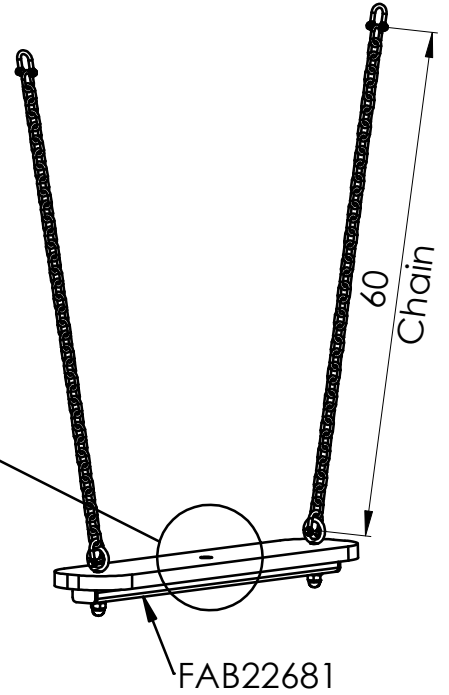
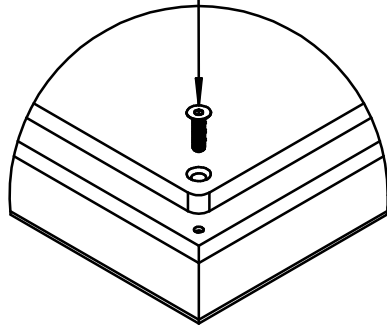

FAB22656

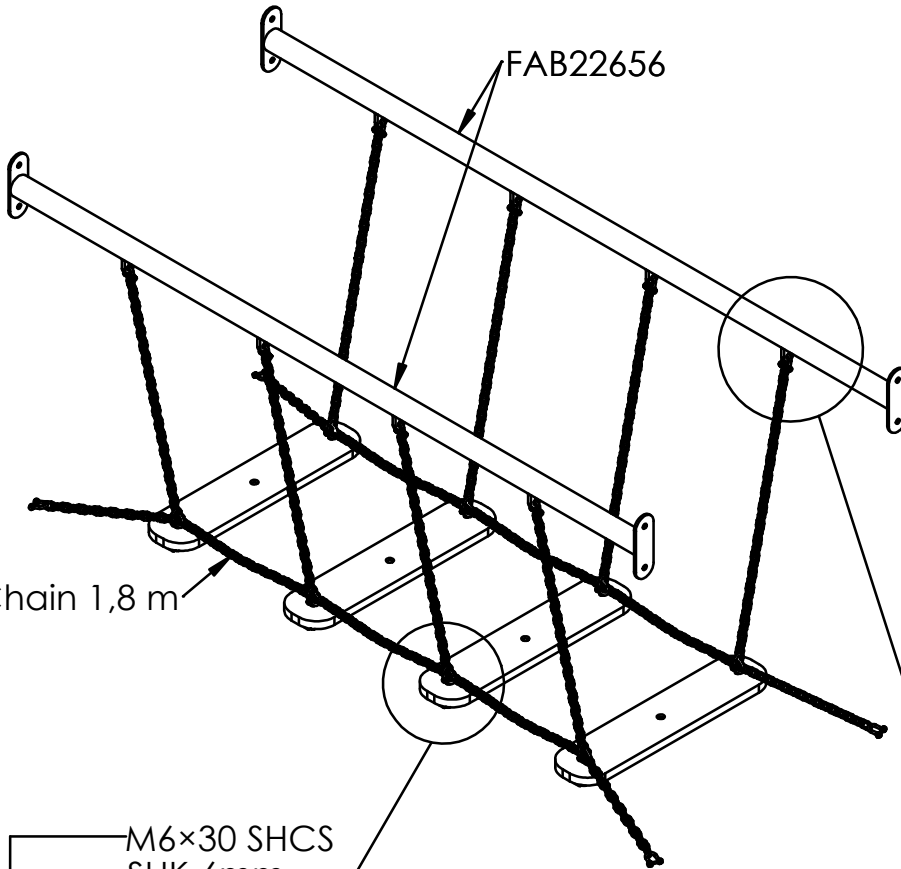

Chain 1,8 m

FAB22681

M6×30 SHCS  
 SHK 6mm  
 M6 SLN

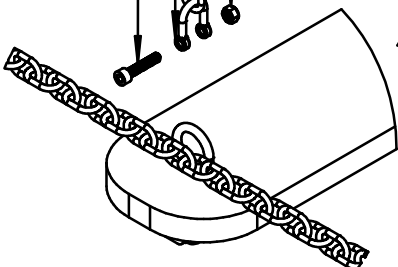

M6×30 SHCS  
 SHK 6mm  
 Chain plug-1

Chain plug-2  
 M6 SLN

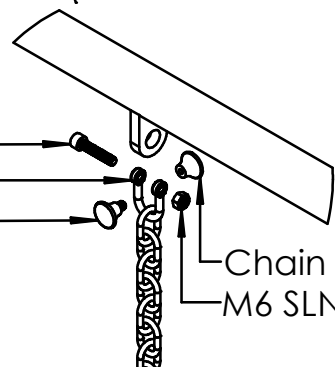

**ASSEMBLY - 2. STRUCTURE**  
**MONTERING – 2. KONSTRUKTION**  
BLFJ027

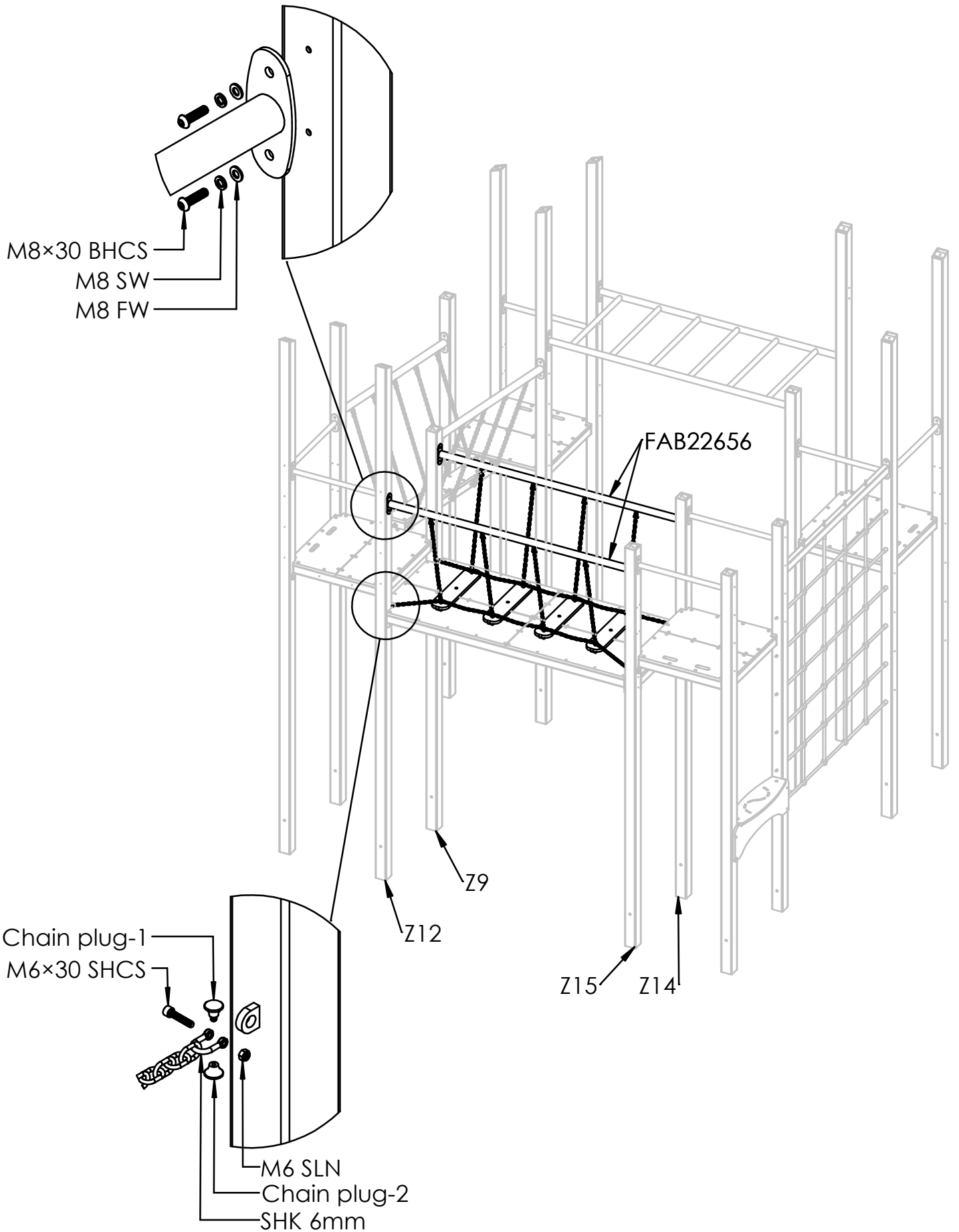

**ASSEMBLY - 2. STRUCTURE**  
**MONTERING – 2. KONSTRUKTION**

BLFJ027

**broa.**

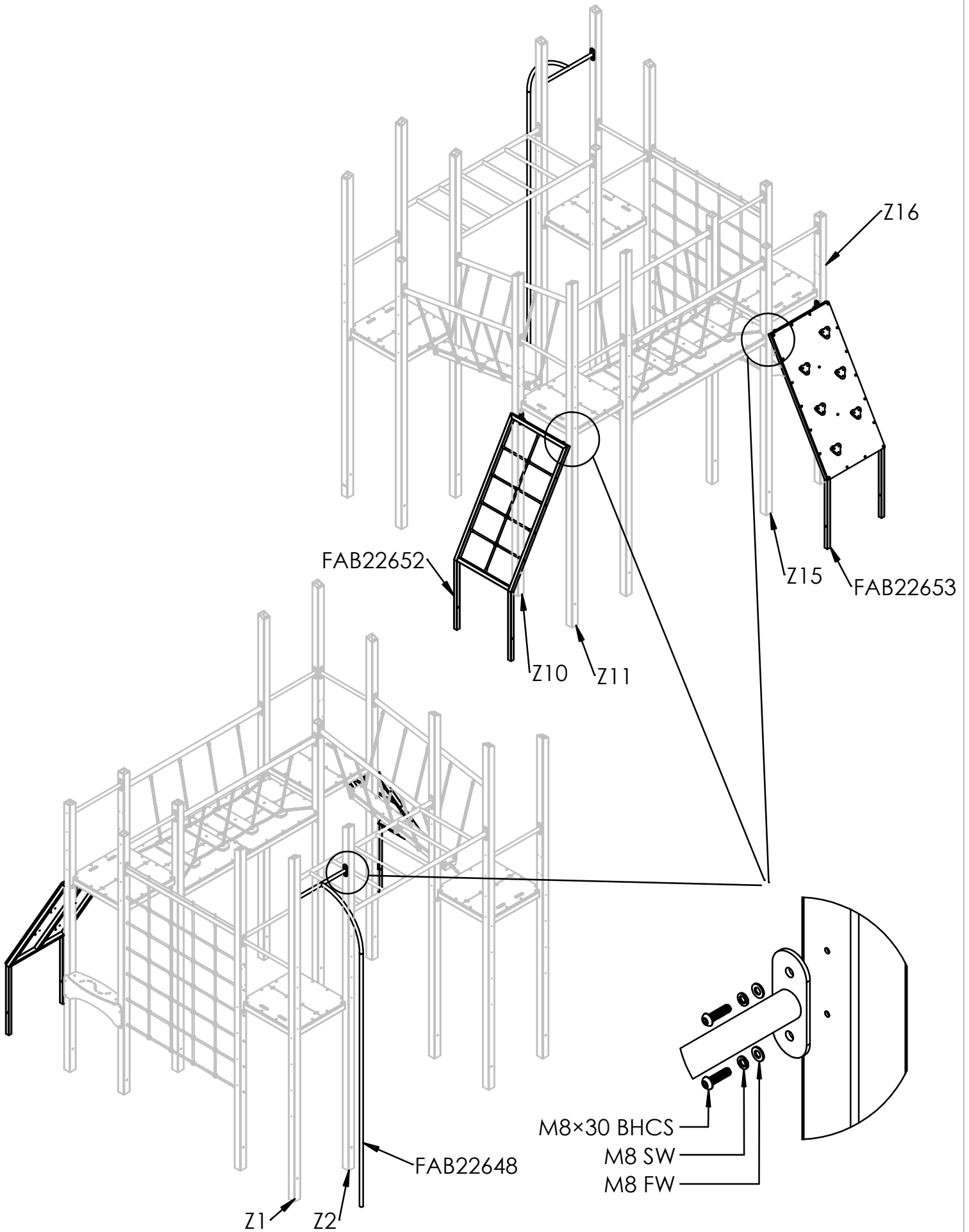

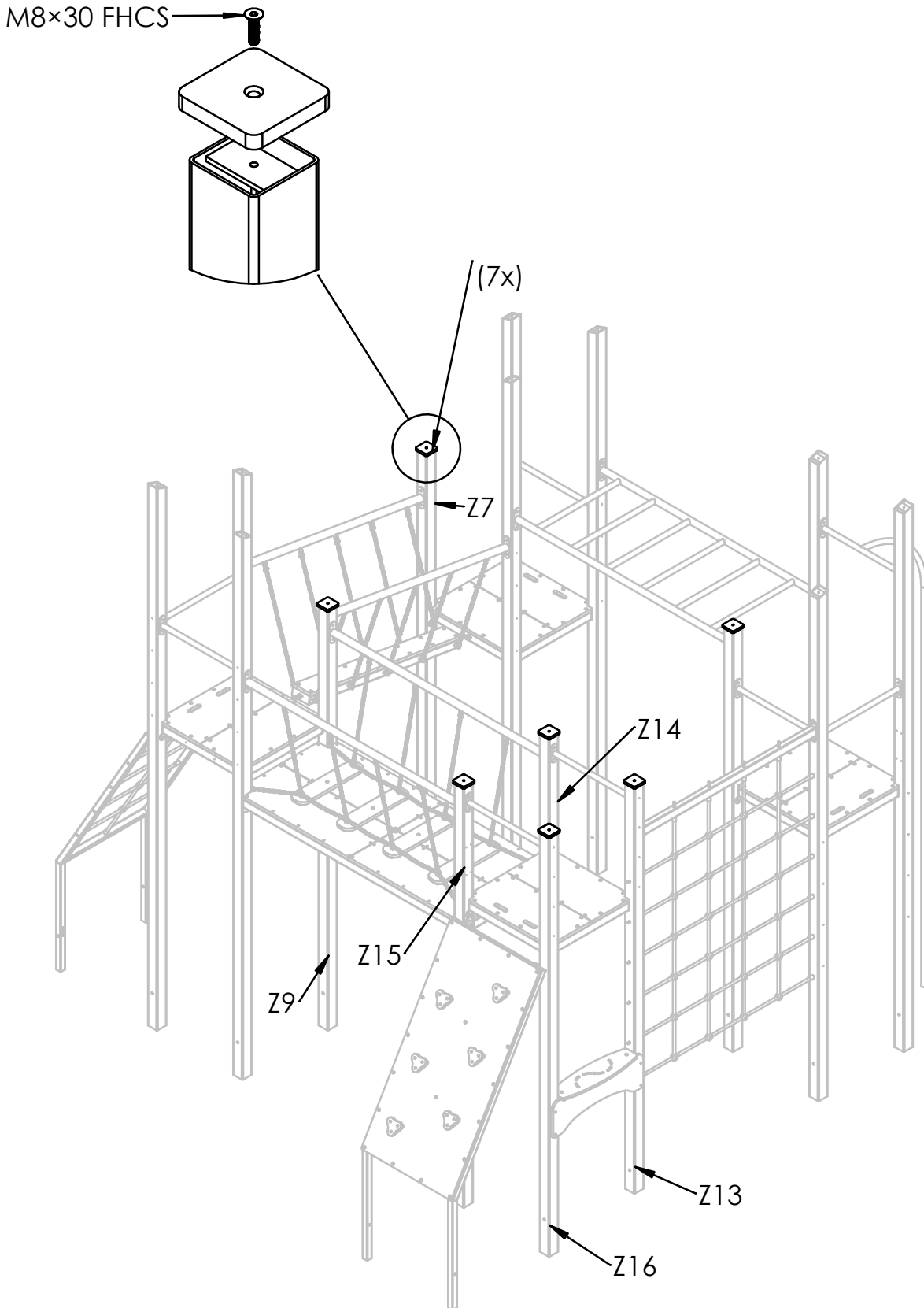

Same fastening method  
applies to all indicated parts.  
Samma fästmetod gäller  
för alla angivna delar.

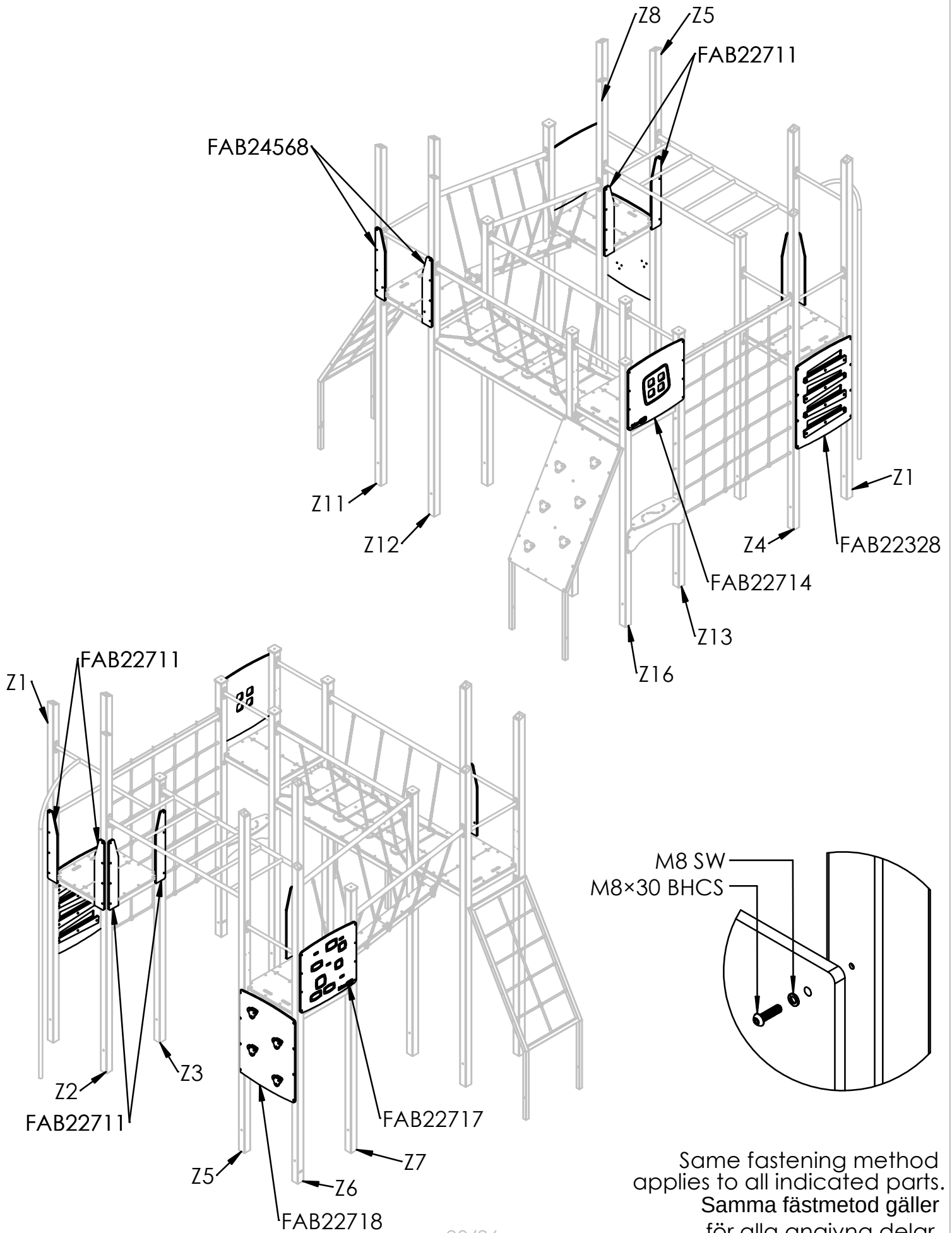

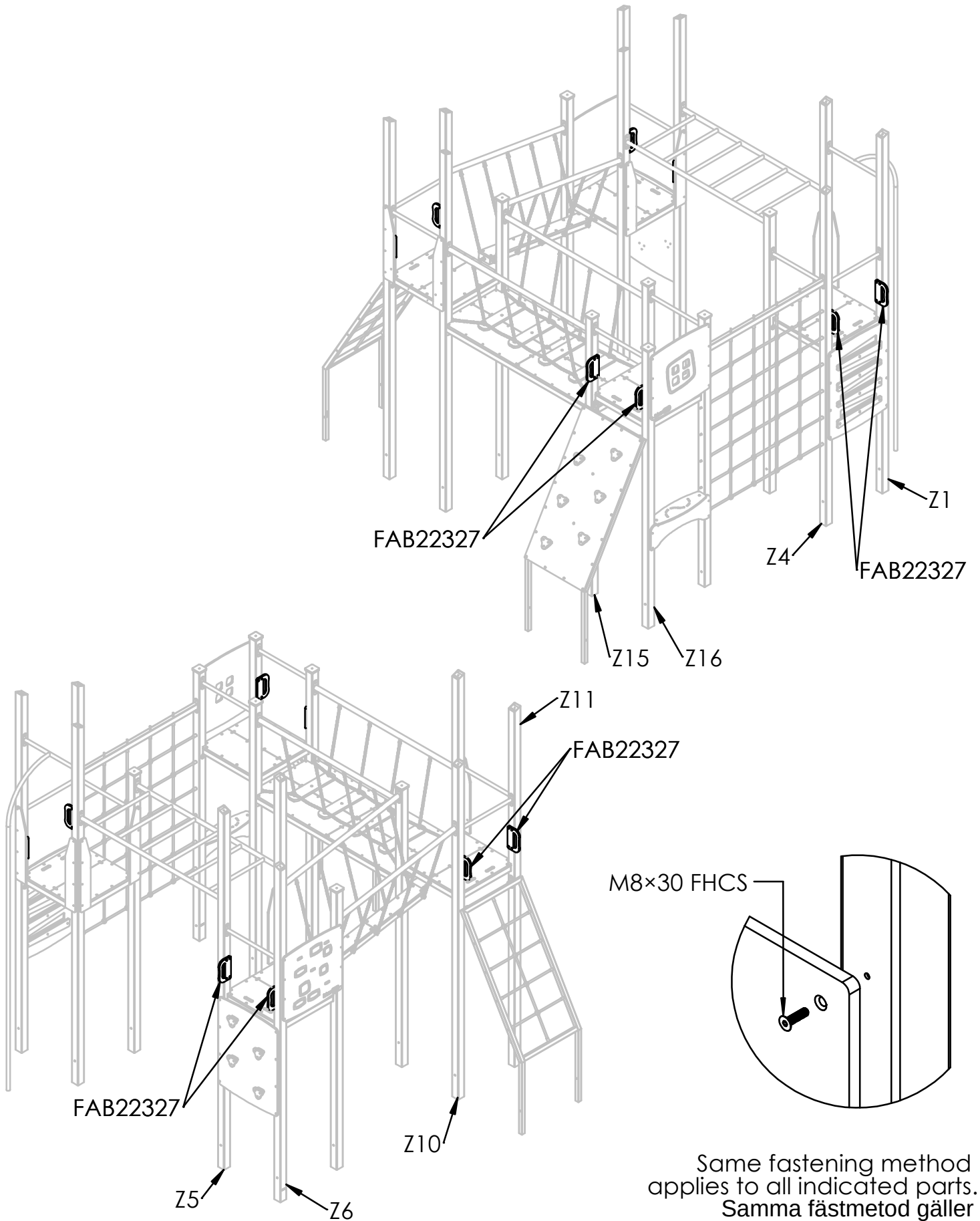

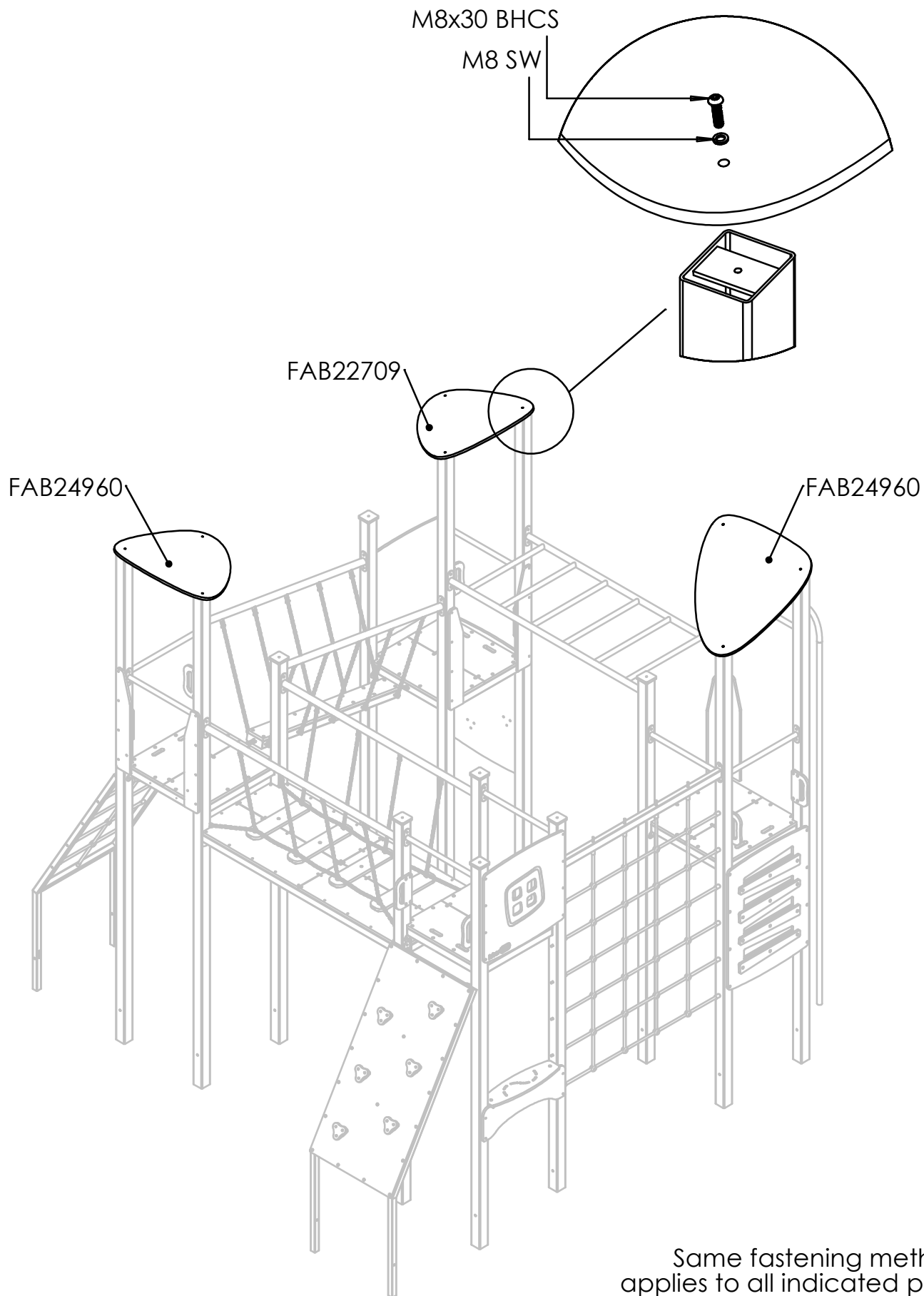

Same fastening method  
applies to all indicated parts.  
Samma fästmetod gäller  
för alla angivna delar.

**ASSEMBLY - 4. SLIDE**  
**MONTERING – 4. RUTSCHKANA**

BLFJ027

**broa.**

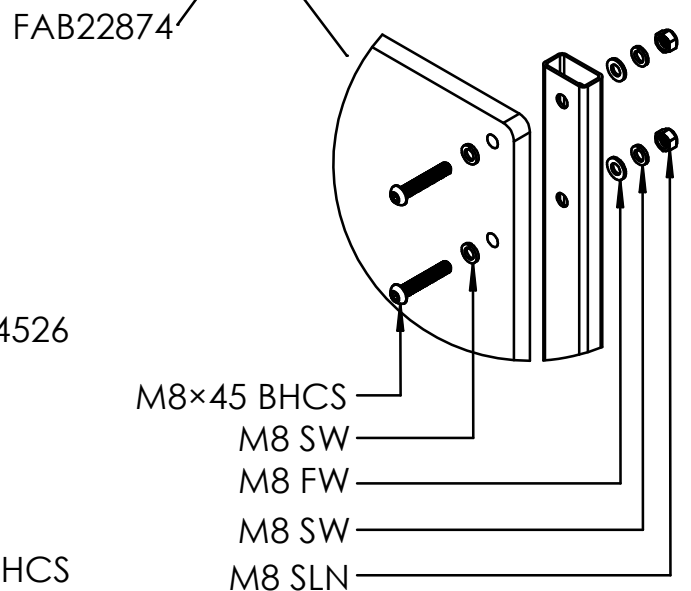
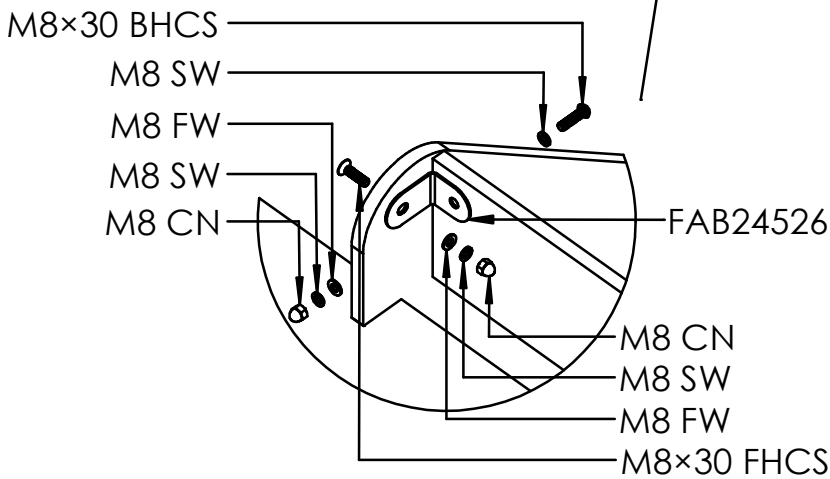
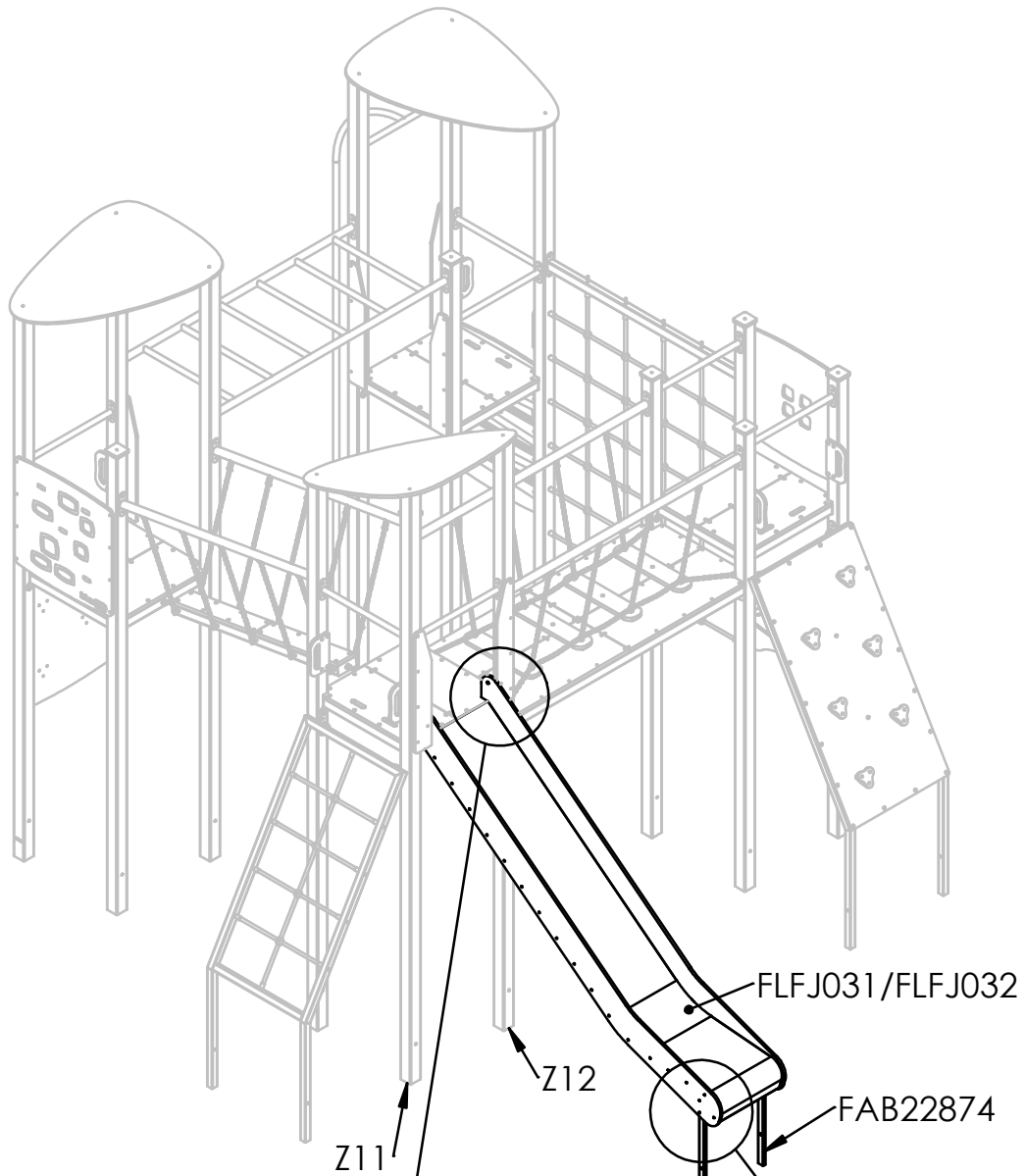

**ASSEMBLY - 4. SLIDE**  
**MONTERING – 4. RUTSCHKANA**  
BLFJ027

Fastening method for stainless steel slide  
Fästmetod för rutschkana i rostfritt stål

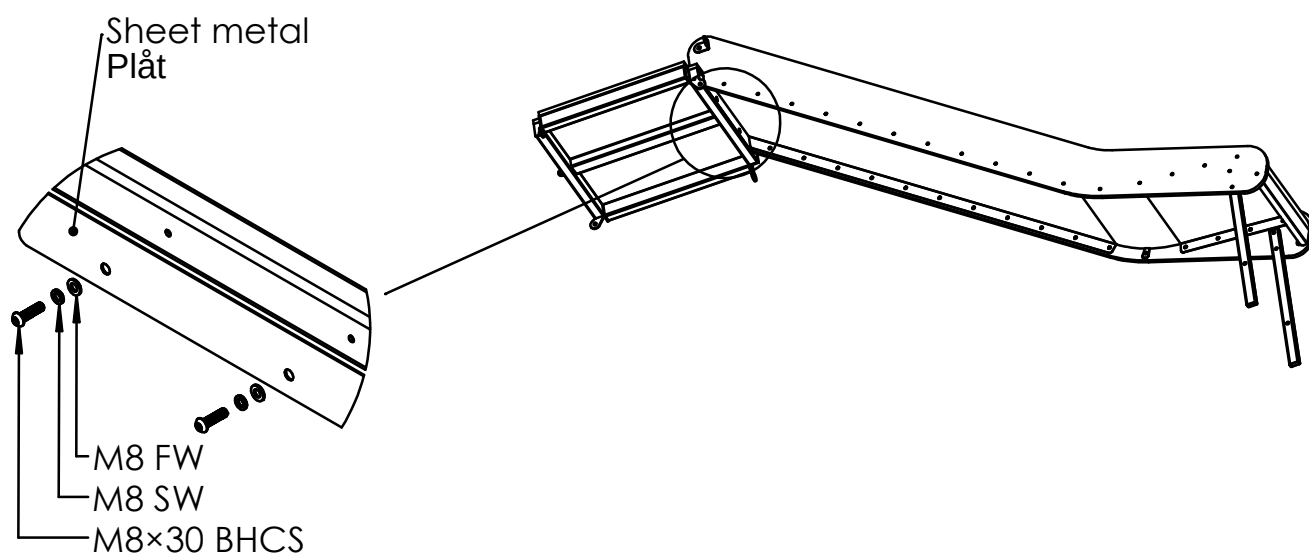
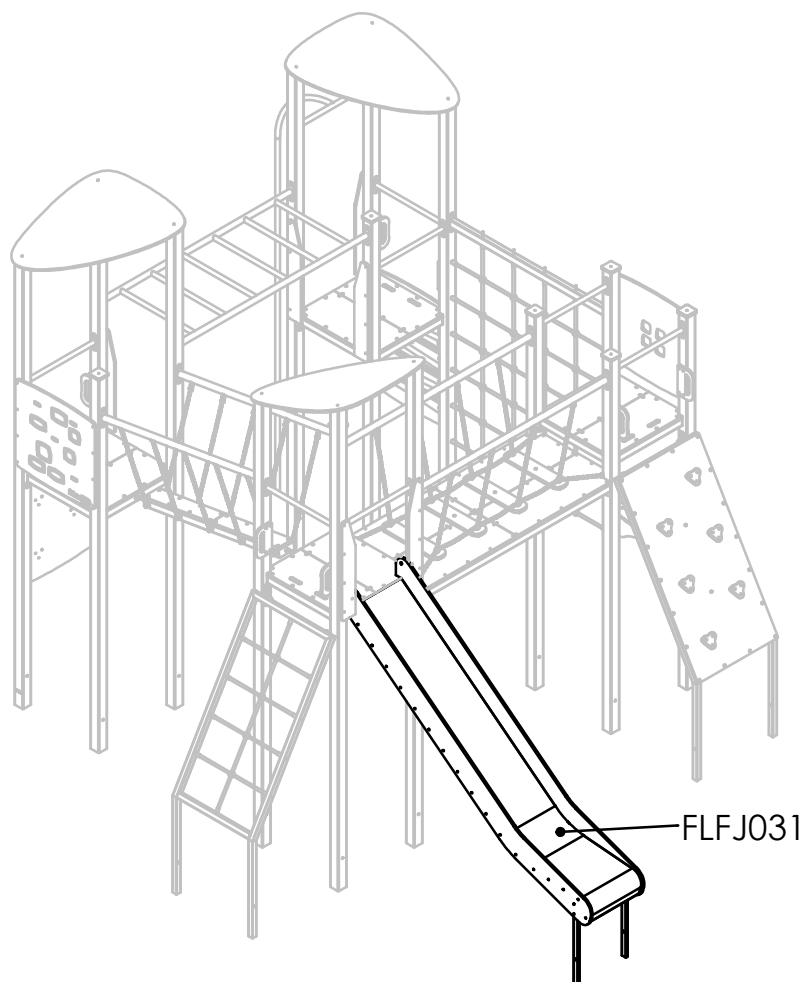

**ASSEMBLY - 4. SLIDE**  
**MONTERING – 4. RUTSCHKANA**  
BLFJ027

Fastening method for polyester slide  
FÄSTMETOD FÖR RUTSCHKANA I POLYESTER

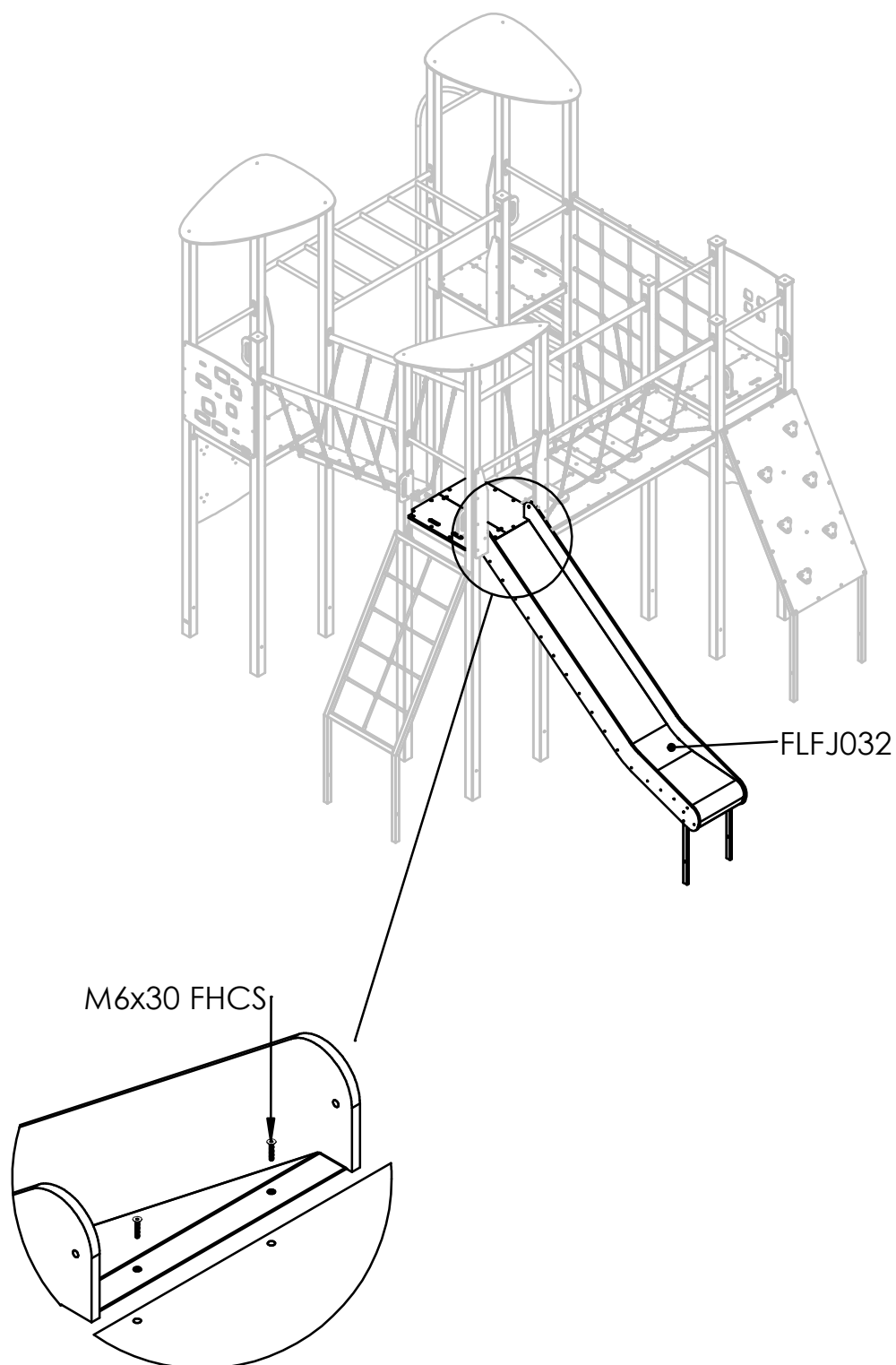

**ASSEMBLY - 5. PRODUCT LABEL**  
**MONTERING – 5. PRODUKTETIKETT**  
BLFJ027

# broa.

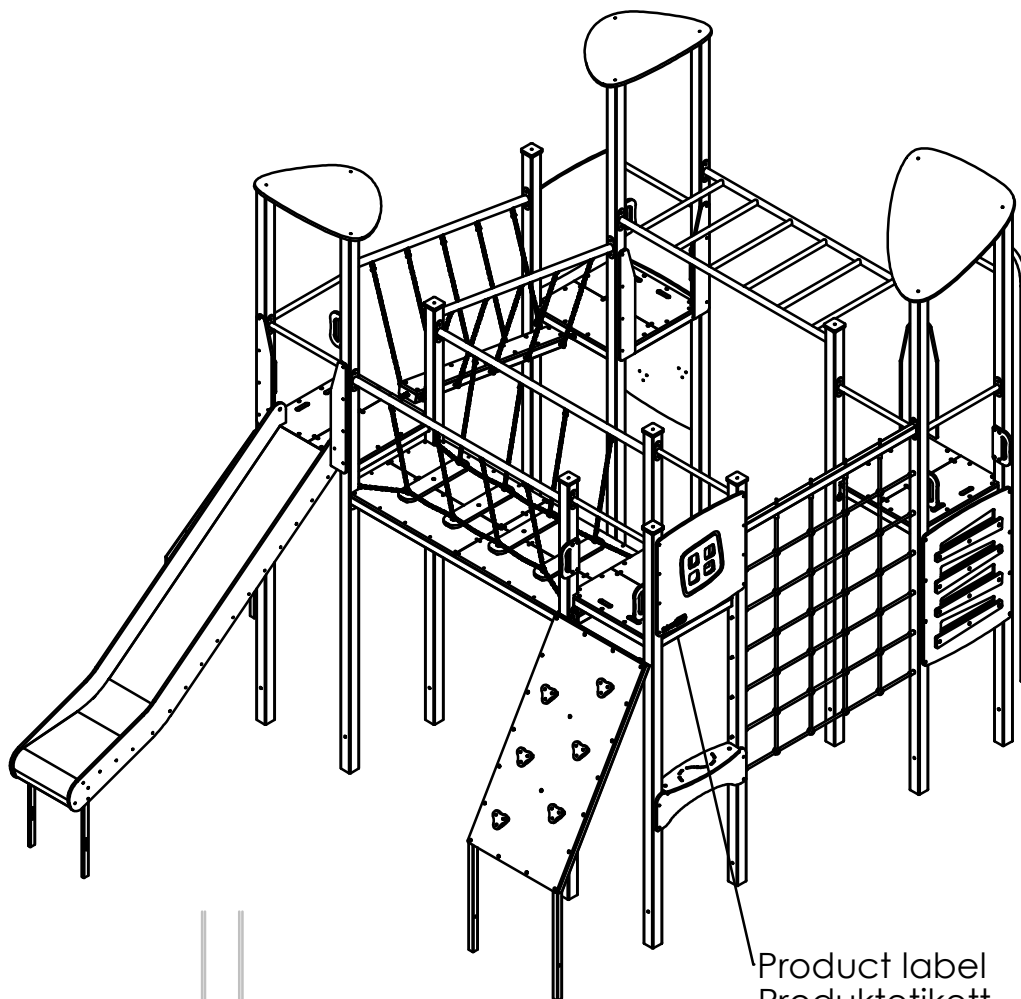

Product label  
Produktetikett

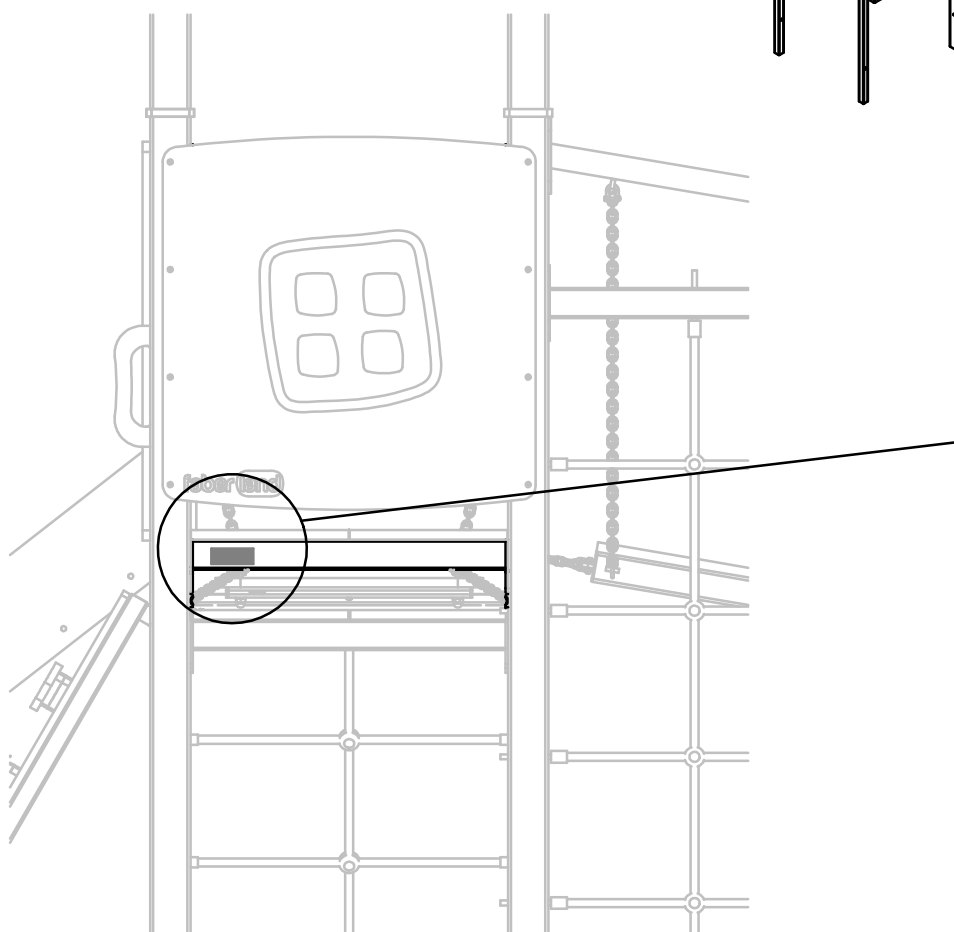

KÖZTARTALOM KOMBINÁLT  
HÉGYTORNÁNY VÁZ

**broa.**

Tervező: 2019.02.07  
Gyártó: Broa Ltd., 2198. Pócsa, Fehérv. 3.  
Szabvány: MSZ EN 1176-1:2017/EN 12566 VIEZ EN 1175:2018  
Állomány: Korcsopart: 514  
Gyártás éve: 2022